

THE INFORMATION AND DESIGN HEREIN WAS ORIGINATED BY AND IS THE PROPERTY OF SKYLOCK INDUSTRIES INCORPORATED. SKYLOCK INDUSTRIES INCORPORATED RESERVES ALL PATENT, PROPRIETARY, DESIGN MANUFACTURING, REPRODUCTION, USE AND SALES RIGHTS THERE TO, AND TO ANY ARTICLE DISCLOSED THEREIN EXCEPT TO THE EXTENT RIGHTS ARE EXPRESSLY GRANTED TO OTHERS. THE FOREGOING DOES NOT APPLY TO VENDOR PROPRIETARY PARTS.

REVISIONS				
ZONE	LTR	DESCRIPTION	DATE	APPROVED
	C	REVISED AND REDRAWN	6-13-91	T. CSIK
	D	ADDED -5	4-28-92	T. CSIK
	E	ADDED -7	4-14-97	T. CSIK

NOTES: UNLESS OTHERWISE SPECIFIED.

- 1 MAT'L: CASE AND HOUSING; ALUM. ALLOY, BOLT AND DETENT; 300 SERIES CRES.
- 2 FINISH: ALUM. PARTS; ANODIZE, CRES PARTS; CLEAN AND PASSIVATE.
- 3 DECORATIVE FINISH: SATIN BUFF IN DIRECTION SHOWN.
- 4 STATIC LOAD: 400 LBS.
- 5 TO ENGAGE BOLT, PUSH HANDLE ON LOWER END. TO DISENGAGE BOLT, PULL HANDLE ON UPPER END.
- 6. BOLT IS DETENTED IN ENGAGED AND DISENGAGED POSITIONS.
- 7 TO ENGAGE BOLT PUSH UP ON LOWER END OF BOLT, TO DISENGAGE PUSH DOWN ON TOP END OF BOLT.

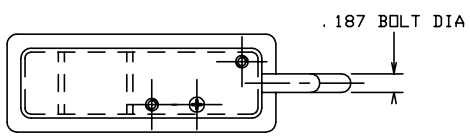
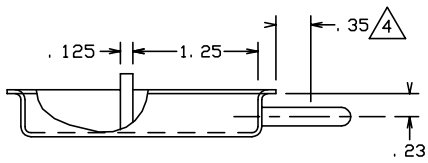
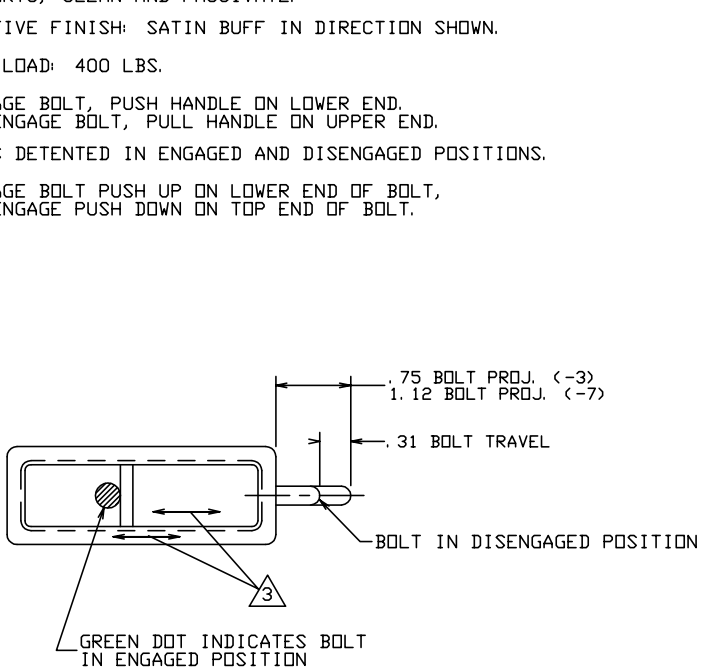

5 -3, -7 LATCH ASSY
(S/A -1 EXCEPT AS SHOWN)

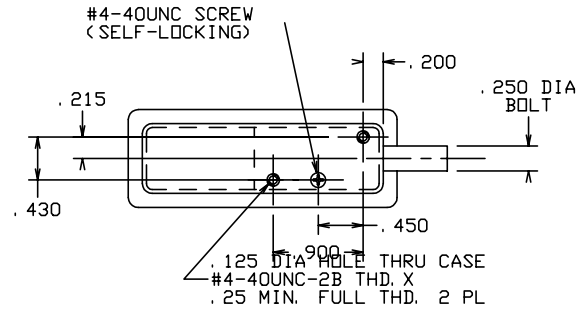
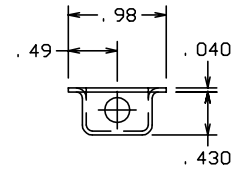
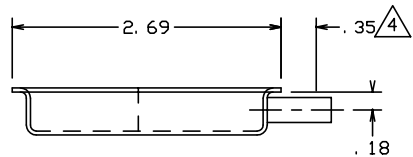
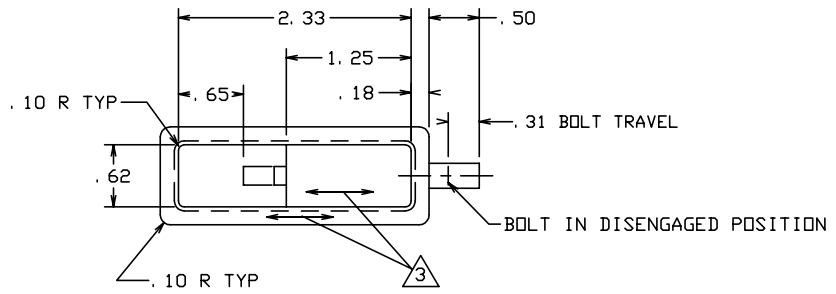

7 -1 LATCH ASSY

	-7	LATCH ASSY	1	2		
	-5	LATCH ASSY	1	2		
	-3	LATCH ASSY	1	2		
	-1	LATCH ASSY	1	2		
PART NO.	DESCRIPTION					

PARTS LIST						
UNLESS OTHERWISE SPECIFIED	DRAWN BY	T. CSIK	6-13-91		SKYLOCK INDUSTRIES INCORPORATED MONROVIA CALIFORNIA U. S. A.	
DIMENSIONS ARE IN INCHES	CHECKED	S. CSIK	6-13-91			
TOLERANCES ON	ENGINEER			LATCH ASSEMBLY- DEADBOLT		
DECIMALS ANGLES DRILLED HOLES	PROJECT					
.X ± .1 ± 0° 30' AND 10387 .XX ± .03 .XXX ± .010	APPROVAL	T. CSIK	6-13-91			
DO NOT SCALE THIS DRAWING	APPROVAL					
MATERIAL - FINISH	USED ON	SIZE	CODE IDENT. NO.	DRAWING NO.	REV.	
NEXT ASSY		C	51941	20159	E	
FINAL ASSY		SCALE	1: 1	WT.	SHEET	1 OF 2

4

3

2

1

REVISIONS				
ZONE	LTR	DESCRIPTION	DATE	APPROVED
		SEE SHT. 1 FOR NOTES.		

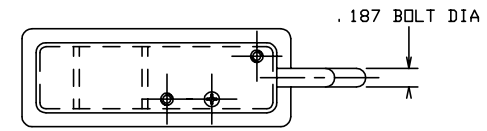
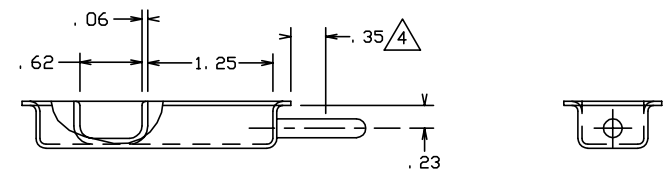
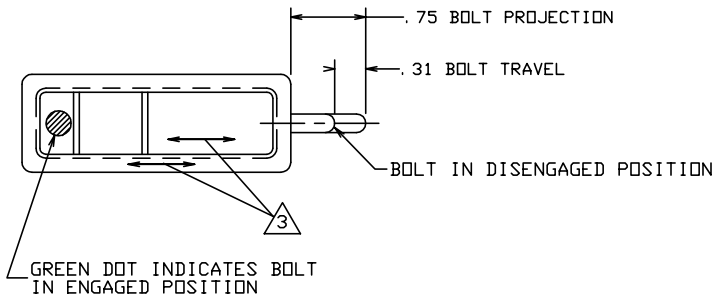

-5 LATCH ASSY
 (S/A -1 EXCEPT AS SHOWN)

 SKYLOCK INDUSTRIES INCORPORATED MONROVIA CALIFORNIA U. S. A.			
LATCH ASSEMBLY- DEADBOLT			
SIZE C	CODE IDENT. NO. 51941	DRAWING NO. 20159	REV. E
SCALE 1: 1	VT.	SHEET 2	OF 2

4

3

2

1