

THE INFORMATION AND DESIGN HEREIN WAS ORIGINATED BY AND IS THE PROPERTY OF SKYLOCK INDUSTRIES INCORPORATED. SKYLOCK INDUSTRIES INCORPORATED RESERVES ALL PATENT, PROPRIETARY, DESIGN MANUFACTURING, REPRODUCTION, USE AND SALES RIGHTS THERE TO, AND TO ANY ARTICLE DISCLOSED THEREIN EXCEPT TO THE EXTENT RIGHTS ARE EXPRESSLY GRANTED TO OTHERS. THE FOREGOING DOES NOT APPLY TO VENDOR PROPRIETARY PARTS.

REVISIONS				
ZONE	LTR	DESCRIPTION	DATE	APPROVED
	A	MAT'L WAS .080 THK	12/3/84	SC
	B	SEE ECN B	4/6/99	TC

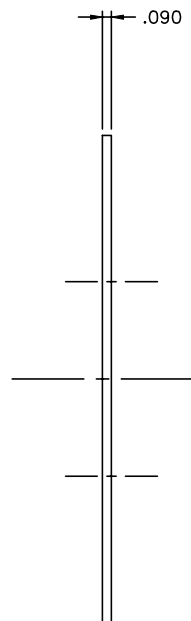
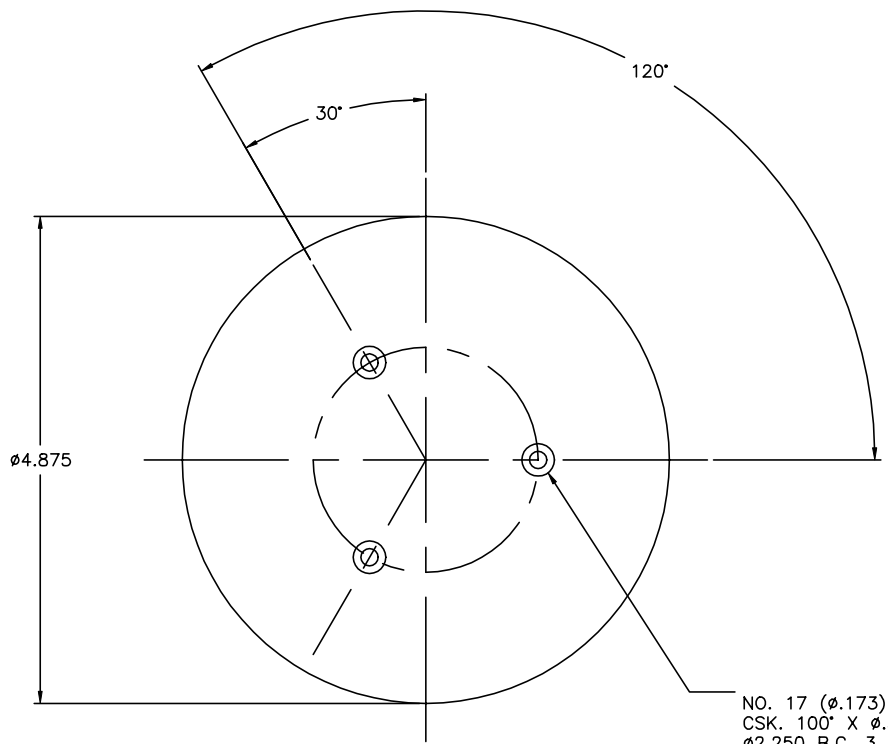

NO. 17 (ø.173) HOLE
CSK. 100° X ø.325
ø2.250 B.C. 3 PLCS

-3

3. FINISH: CLEAR ANODIZE PER MIL-A-8625, TYPE II, CLASS 1.
2. MAT'L: 6061-T6/T651 PER ASTM B-209, OR EQUIV.
1. REMOVE ALL BURRS AND SHARP CORNERS

NOTES: UNLESS OTHERWISE SPECIFIED:

-3 BACKPLATE		MATERIAL SIZE APPLICATION		ITEM NO.
QTY. REQD.	PART NO.	DESCRIPTION	MATERIAL	SIZE APPLICATION
PARTS LIST				
UNLESS OTHERWISE SPECIFIED		DRAWN BY	M. FOSTER	12/3/84
DIMENSIONS ARE IN INCHES		CHECKED	ED WELSH	3/26/99
TOLERANCES ON		ENGINEER	T.CSIK	4/6/99
DECIMALS	ANGLES	DRILLED HOLES	MFG.	P. MATSUOKA
.X .1	0° 30'	AND 10367	4/12/99	
.XX .03			Q. A.	J. VIVIRITO
.XXX .010				4/12/99
DO NOT SCALE THIS DRAWING				
MATERIAL - FINISH		USED ON	20201	SIZE
NEXT ASSY				C
FINAL ASSY				51941
				20177
				B
				SCALE 1:1
				WT.
				SHEET 1 OF 1



BACKPLATE