

THE INFORMATION AND DESIGN HEREIN WAS ORIGINATED BY AND IS THE PROPERTY OF WYLOXK INDUSTRIES INCORPORATED. WYLOXK INDUSTRIES INCORPORATED RESERVES ALL PATENT, PROPRIETARY, DESIGN MANUFACTURING INFORMATION, USE AND SALES RIGHTS HEREIN, AND TO ANY ARTICLES DEVELOPED THEREIN EXCEPT TO THE EXTENT RIGHTS ARE EXPRESSLY GRANTED TO OTHERS. THE FOREGOING DOES NOT APPLY TO NON-PATENTABLE MATTER.

REVISIONS				
ZONE	LTR	DESCRIPTION	DATE	APPROVED
D		REDRAWN, ADDED -13	4-30-98	T. C.
E		SEE ECN E		

NOTES: UNLESS OTHERWISE SPECIFIED.

- MAT'L REF.: KNOB, ESCUTCHEON AND CASE; 6061-T6 PER ASTM B-209, ASTM B-221 OR EQUIV. BUSHING & BOLT; NATURAL DELRIN, PER ASTM-D-4181 OR EQUIV. SPRINGS AND ALL OTHER COMPS; 303 CRES, COND. A, PER AMS-5640N OR EQUIV.
- PROTECTIVE FINISH REF.: ALUM.; CLEAR ANODIZE PER MIL-A-8625, TYPE II, CLASS 1 OR EQUIV. CRES; PASSIVATE PER AMS-QQ-P-35, TYPE II OR EQUIV. STEEL; CADMIUM PLATE PER QQ-P-416, TYPE II, CLASS 1 OR EQUIV.
- DECORATIVE FINISH REF.: SATIN BRUSH DIRECTION NOTED AND CLEAR-ANODIZE PER MIL-A-8625, TYPE II, CLASS 1 OR EQUIV.
- OPERATION: ON 'G' SIDE, KEY RETRACTS BOLT. ON 'R' SIDE, KNOB RETRACTS BOLT AT ANY TIME. BOLT IS SPRING LOADED TO ENGAGED POSITION.
- LATCH IS REPAIRABLE PER ATA 100.
- ORDER: TO ORDER LATCH WITH REVERSE BEVEL, ADD SUFFIX 'R' TO PART NO. AS SHOWN, EXAMPLE; 20247-1-R.
- USE WITH STRIKER NO. 20258.
- PART -1, -7, -13 HAVE RUBBER BUMPER ON 'G' SIDE.
- PART -3 HAS RUBBER BUMPER ON BOTH SIDES.
- PART -5 HAS DECORATIVE ACRYLIC PLASTIC INSTEAD OF BUMPER.
- PART -9 & -11 HAS RUBBER BUMPER ON 'R' SIDE ONLY.
- DECORATIVE FINISH REF.: BRIGHT POLISH, AND GOLD PLATE VISIBLE SURFACES.

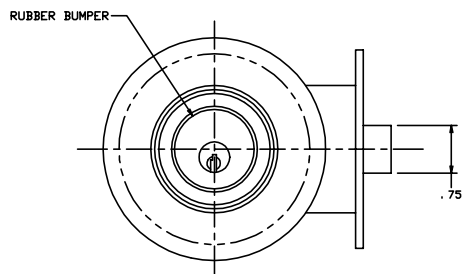
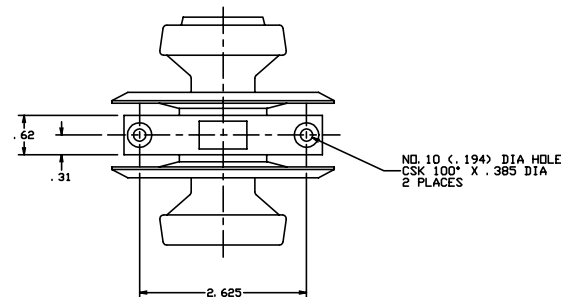
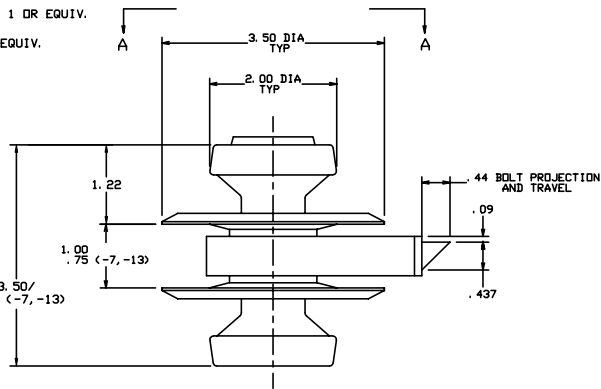

VIEW A-A
G SIDE

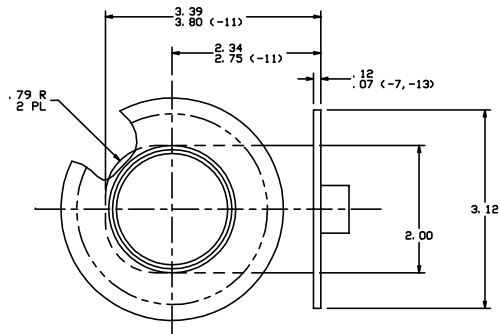

R SIDE

QTY REQD	PART NO.	DESCRIPTION	MATERIAL	SIZE	SPECIFICATION	WAVE FROM
	-13	LATCH ASSY				120247-13
	-11	LATCH ASSY				120247-11
	-9	LATCH ASSY				120247-9
	-7	LATCH ASSY				120247-7
	-5	LATCH ASSY				120247-5
	-3	LATCH ASSY				120247-3
	-1	LATCH ASSY				120247-1

PARTS LIST			
UNLESS OTHERWISE SPECIFIED		DRAWN BY	JEE
DIMENSIONS ARE IN INCHES		CHECKED	1-10-78
TOLERANCES ON		WYLOXK INDUSTRIES INCORPORATED MONROVIA CALIFORNIA	
DECIMALS	ANGLES	DRIVENER	
.0001	1/16°	MFG	
.0005	1/32°	QC	
.001	1/64°	DO NOT SCALE THIS DRAWING	
.005	1/32°	MATERIAL - FINISH	
.01	1/16°	USED ON	
.03	1/8°	SIZE	
.05	1/4°	CODE IDENT. NO.	
.1	1/2°	DRAWING NO.	
.2	1°	REV.	
.5	2°	D 51941 20247 E	
1	4°	MANUFACTURE IN ACCORDANCE WITH WYLOXK IND. INC., QUALITY CONTROL MANUAL, QC 001	
2	8°	SCALE 1:1	
3	16°	SHEET 1 OF 1	