

THE INFORMATION AND DESIGN HEREIN WAS ORIGINATED BY AND IS THE PROPERTY OF SKYLOCK INDUSTRIES INCORPORATED. SKYLOCK INDUSTRIES INCORPORATED RESERVES ALL PATENT, PROPRIETARY, DESIGN MANUFACTURING, REPRODUCTION, USE AND SALES RIGHTS THEREOF, AND TO ANY ARTICLE DISCLOSED THEREIN EXCEPT TO THE EXTENT RIGHTS ARE EXPRESSLY GRANTED TO OTHERS. THE FOREGOING DOES NOT APPLY TO VENDOR PROPRIETARY PARTS.

NOTES: UNLESS OTHERWISE SPECIFIED.

1. MATERIAL: CASE ASSY, ACTUATOR KNOB - ALUM. ALLOY; INDICATOR SIGN AND WINDOW - TRANSLUCENT PLASTIC; BOLT AND ALL OTHER COMPONENTS - CRES.
2. DECORATIVE FINISH: ALL VISIBLE METAL SURFACES - SATIN BUFF.
3. PROTECTIVE FINISH: ALUM. - CLEAR ANODIZE; CRES - PASSIVATE.
4. INDICATOR SIGN: SEE SECONDARY DASH NO. FOR LETTERING DESCRIPTION.
5. LATCH IS SPRING BIASED TO THE EXTENDED OR RETRACTED POSITIONS.
6. LIGHT FROM LAVATORY SIDE ILLUMINATES INDICATOR SIGN THRU TRANSLUCENT WINDOW.
7. LATCH OPERATION: LAVATORY SIDE ACTUATOR KNOB EXTENDS AND RETRACTS BOLT. INDICATOR SIGN READS 'VACANT' (OR EQUIV.) WHEN BOLT IS RETRACTED, AND 'OCCUPIED' (OR EQUIV.) WHEN BOLT IS EXTENDED.

8. INDICATOR SIGN SHOWS UNLOCKED/LOCKED SYMBOLGY AS SHOWN BELOW:

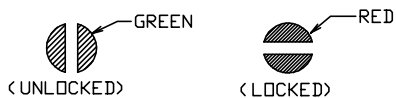

REVISIONS				
ZONE	LTR	DESCRIPTION	DATE	APPROVED
	NC	PRODUCTION RELEASE	1-31-78	J. E. E.
	A	REDRAWN ON CADAM, ADDED -7, -8	8-24-94	T. CSIK
	B	ADDED SECONDARY DASH NO.	5-31-95	T. CSIK
	C	SEE ECN C	7/7/99	TANY B.

8	-8	LATCH ASSY	<DPP., WITH KNOB AND ESCUTCHEONS>
8	-7	LATCH ASSY	<SHOWN, WITH KNOB AND ESCUTCHEONS>
4	-6	LATCH ASSY	<DPP., WITH KNOB WITHOUT ESCUTCHEONS>
4	-5	LATCH ASSY	<SHOWN, WITH KNOB WITHOUT ESCUTCHEONS>
4	-4	LATCH ASSY	<DPP., WITH KNOB AND ESCUTCHEONS>
4	-3	LATCH ASSY	<SHOWN, WITH KNOB AND ESCUTCHEONS>
4	-2	LATCH ASSY	<DPP., WITHOUT KNOB AND ESCUTCHEONS>
4	-1	LATCH ASSY	<SHOWN, WITHOUT KNOB AND ESCUTCHEONS>
	PRIMARY DASH NO.	DESCRIPTION	MATERIAL SIZE SPECIFICATION

PARTS LIST			
UNLESS OTHERWISE SPECIFIED: DIMENSIONS IN INCHES DECIMALS .X * .1 .XX * .020 .XXX * .010 DIMENSIONS IN MILLIMETERS DECIMALS .X * .1 MM .XX * .20 MM	DRAWN BY	T. CSIK	8-24-94
	CHECKED	ED WELSH	7/7/99
	ENGINEER	TANY B.	7/7/99
	MFG	P. MATSUOKA	7/7/99
	QC	J. VIVIRITO	7/7/99
DO NOT SCALE THIS DRAWING NEXT ASSY			USED ON SIZE CODE IDENT. NO. DRAWING NO. REV. C 51941 20253 C
SCALE 1:2 WT. .25 KG/.60 LB.			SHEET 1 OF 2

20253-1-1 20253-2-1	BLACK	HELVETICA BOLD, .15"	BERISI KOSONG (INDONESIAN) OCCUPIED VACANT (ENGLISH)
20253-1 20253-2	BLACK	HELVETICA BOLD, .25"	OCCUPIED/VACANT (ENGLISH)
SECONDARY DASH NO.	COLOR	FONT STYLE AND SIZE	INDICATOR SIGN TO READ

THE INFORMATION AND DESIGN HEREIN WAS ORIGINATED BY AND IS THE PROPERTY OF SKYLOCK INDUSTRIES INCORPORATED. SKYLOCK INDUSTRIES INCORPORATED RESERVES ALL PATENT, PROPRIETARY, DESIGN MANUFACTURING, REPRODUCTION, USE AND SALES RIGHTS THERE TO, AND TO ANY ARTICLE DISCLOSED THEREIN EXCEPT TO THE EXTENT RIGHTS ARE EXPRESSLY GRANTED TO OTHERS. THE FOREGOING DOES NOT APPLY TO VENDOR PROPRIETARY PARTS.

REVISIONS				
ZONE	LTR	DESCRIPTION	DATE	APPROVED
		SEE SHT. 1 FOR NOTES	7/7/99	TANY B.

D
C
B
A

D
C
B
A

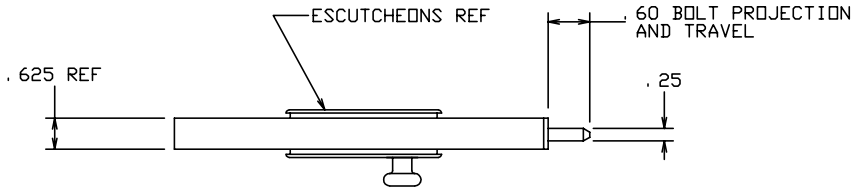
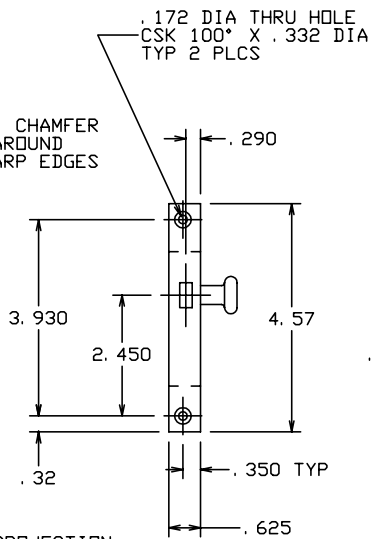
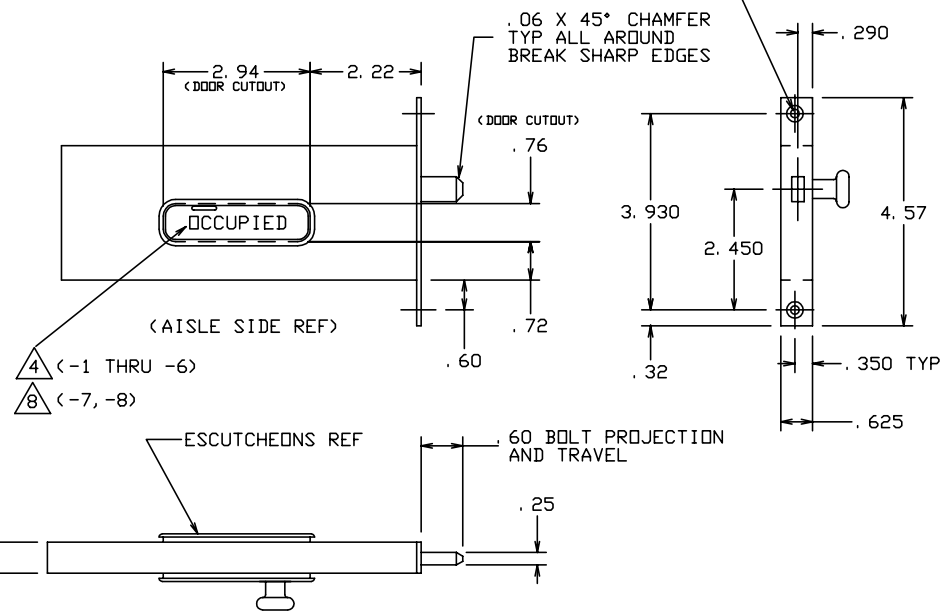

-1 LATCH ASSY (SHOWN)
-2 LATCH ASSY (OPP.)

 SKYLOCK INDUSTRIES INCORPORATED MONROVIA CALIFORNIA U. S. A.			
INDICATOR LATCH ASSY			
SIZE C	CODE IDENT. NO. 51941	DRAWING NO. 20253	REV. C
SCALE 1: 2	WT. .25 KG / .60 LB.	SHEET 2	OF 2

4

3

2

1