

THE INFORMATION AND DESIGN HEREIN WAS ORIGINATED BY AND IS THE PROPERTY OF SKYLOCK INDUSTRIES INCORPORATED. SKYLOCK INDUSTRIES INCORPORATED RESERVES ALL PATENT, PROPRIETARY, DESIGN MANUFACTURING, REPRODUCTION, USE AND SALES RIGHTS THERE TO, AND TO ANY ARTICLE DISCLOSED THEREIN EXCEPT TO THE EXTENT RIGHTS ARE EXPRESSLY GRANTED TO OTHERS. THE FOREGOING DOES NOT APPLY TO VENDOR PROPRIETARY PARTS.

SECOND DASH NO.	DIM B	DIM C
-1	.34	.64
-3	.19	.49
-5	.34	.49

REVISIONS			DATE	APPROVED
ZONE	LTR	DESCRIPTION		
	F	SEE ECN F	10/1/99	T. C.

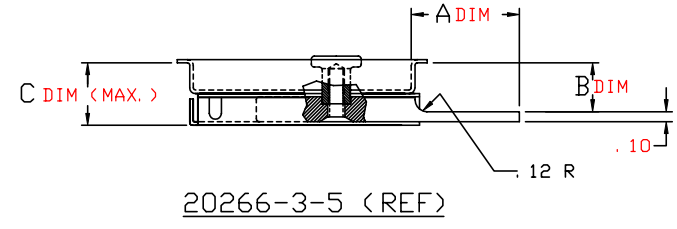
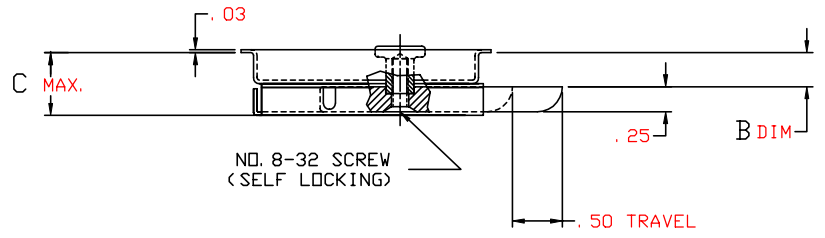
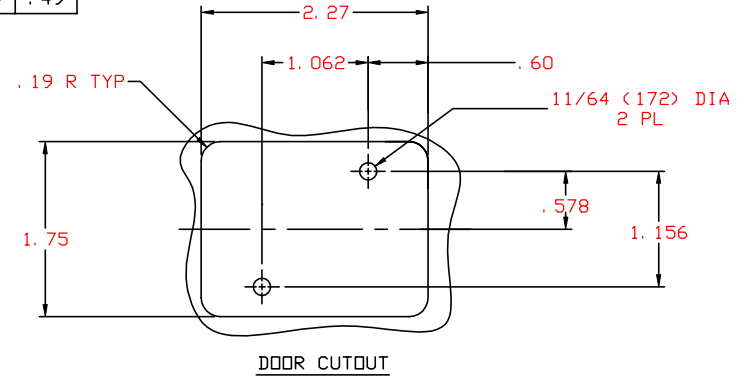
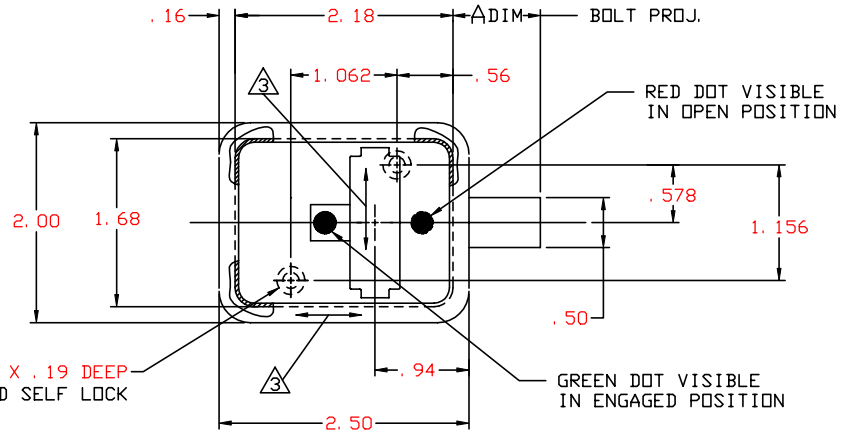

- 7. APPLICABLE TO FAA-PMA REPLACEMENT OR MODIFICATION PARTS ONLY. PER FAR 45.15, PARTS WILL BE IDENTIFIED WITH:
  1. FAA-PMA.
  2. SKYLOCK IND. INC.
  3. PART NO.
  4. AIRCRAFT INSTALLATION ELIGIBILITY.

6. EXAMPLE PART NO.: 20266-3-3  
 BASIC PART NO. | 1.19 SHALLOW CASE  
 | 1.12 BOLT PROJ.

- 5. BOLT IS DETENTED IN EXTENDED AND RETRACTED POSITION.
- 4. THE FOLLOWING STATIC LOAD IS FOR REFERENCE USE ONLY. IT IS PROVIDED FOR CUSTOMER ENGINEERING TO DETERMINE THE GENERAL SUITABILITY OF THE PRODUCT FOR ITS INTENDED USE. ALTHOUGH SKYLOCK IS PROVIDING THE REFERENCE STATIC LOAD, THE CUSTOMER IS ULTIMATELY RESPONSIBLE FOR CERTIFICATION OF THE PRODUCT FOR ITS SPECIFIC APPLICATION. REFERENCE STATIC LOAD: 600 LBS. MAX.

- 3. DECORATIVE FINISH REF.: SATIN BRUSH, DIRECTION NOTED.
- 2. FINISH REF.: HANDLE; CLEAR ANODIZE PER MIL-A-8625, TYPE II, CLASS 1, OR EQUIV. CRES PARTS; PASSIVATE PER AMS-QQ-P-35, TYPE II, OR EQUIV.
- 1. MATL REF.: HANDLE; 6061-T6/T651, PER ASTM B-221, OR EQUIV. ALL OTHER PARTS; 303 CRES, COND. A, PER AMS-5640N OR EQUIV.

REMOVE ALL BURRS AND SHARP CORNERS.  
 NOTES: UNLESS OTHERWISE SPECIFIED

.81	-7	LATCH		
1.06	-5	LATCH		
1.12	-3	LATCH		
.91	-1	LATCH		
ADIM	PART NO.	DESCRIPTION	MATERIAL	SIZE APPLICATION

PARTS LIST		DRAWN BY		JEE		4/13/78	
UNLESS OTHERWISE SPECIFIED		CHECKED		L. GARCIA		3/10/99	
DIMENSIONS ARE IN INCHES		ENGINEER		T. CSIK		3/12/99	
TOLERANCES ON		MFG		P. MATSUOKA		3/15/99	
DECIMALS		QC		J. VIVIRITO		3/18/99	
ANGLES							
DRILLED HOLES							
.X ± .1 ± 0° 30' AND 10387							
.XX ± .03							
.XXX ± .010							
DO NOT SCALE THIS DRAWING							
MATERIAL - FINISH		USED ON		SIZE	CODE IDENT. NO.	DRAWING NO.	REV.
				C	51941	20266	F
NEXT ASSY				SCALE 1:1		WT.	SHEET 1 OF 1
MANUFACTURE IN ACCORDANCE WITH SKYLOCK IND. INC., QUALITY CONTROL MANUAL QC.001							

SKYLOCK INDUSTRIES INCORPORATED  
 MONROVIA CALIFORNIA U. S. A.

20266 LATCH