

DIM.	DASH NO.
1.250	-1
2.312	-3

ITEM	DESCRIPTION		DATE	BY
	EFFECTIVE ON	DISP EXIST PART		APPROVAL
A	ADDED TABULATION 4-3 LATCH		8-10-82	JWF
B	SEE DCN 10918		8-22-85	PRS
C	ADDED -5		4-23-93	TTC.

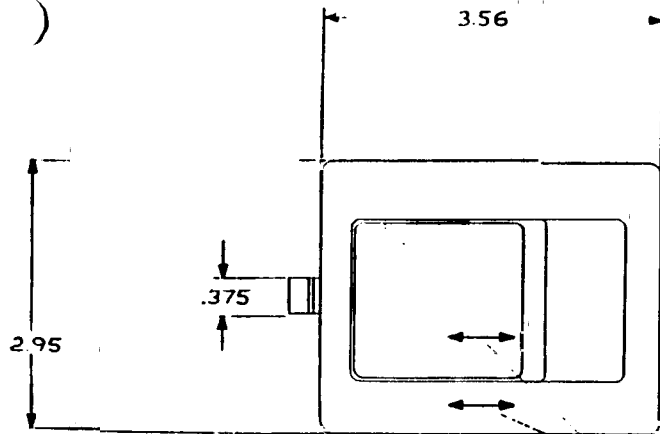

3 GRAIN DIRECTION

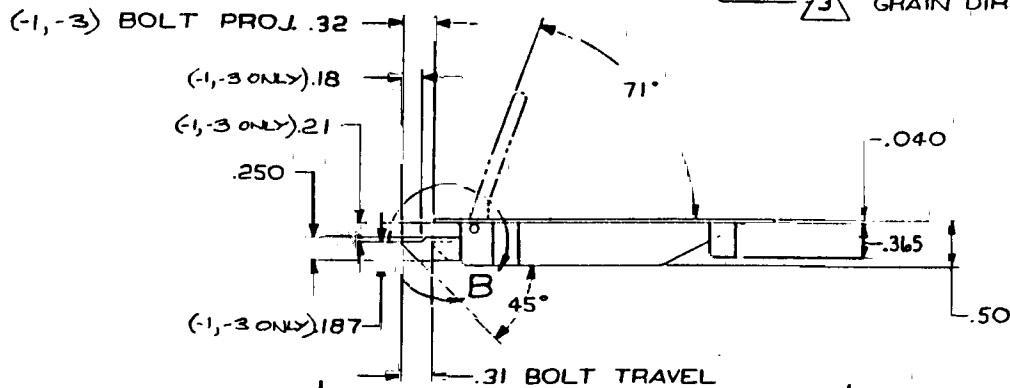

A

A

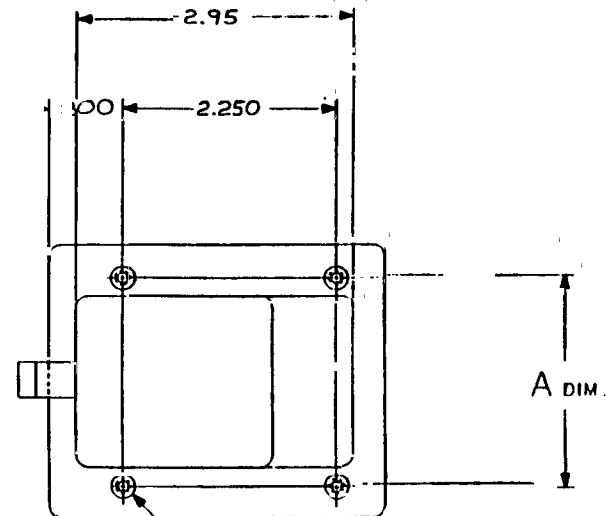
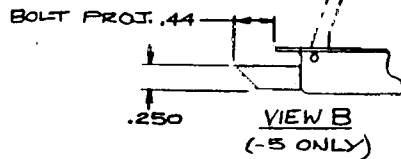

- No. 6-32UNC-2B THREADED STUD
TYP 4 PL (-1,-3 ONLY)

VIEW A-A

4. STATIC LOAD : 600 LB

3 DECORATIVE FINISH : SATIN BUFF

2 FINISH : PASSIVATE

1 MAT'L : 300 SERIES CRES

NOTES : UNLESS OTHERWISE SPECIFIED

REQD	PART NUMBER	DESCRIPTION	MATERIAL OR NOTE
	-5	LATCH ASSY	(SAME AS -1 EXCEPT AS SHOWN)
	-3	LATCH ASSY	
	-1	LATCH ASSY	

LIST OF MATERIAL			
UNLESS OTHERWISE NOTED DIMENSIONS ARE IN INCHES. TOLERANCES ON: DECIMALS XX ± .03 XXX ± .010 ANGLES ± DRILLED HOLES PER ANSI Q307		CONTRACT NO. 8	
SURFACE ROUGHNESS		DRAFTSMAN JEE	1/13/74
HEAT TREAT		CHECKER	
FINISH		ENGINEER JEE	1/13/74
INSPECT		PROD. APPD	
REF. NO.		APPROVAL	
NEXT ASSY	USED ON	SIZE	CODE IDENT NO.
APPLICATION		C	51941
		SCALE	WT CALC
		WT ACT	SHEET 1 OF 1

SKYLOCK INDUSTRIES, INC.
50. EL MONTE, CALIFORNIA

LATCH ASSEMBLY

20335

C