

4

3

2

1

THE INFORMATION AND DESIGN HEREIN WAS ORIGINATED BY AND IS THE PROPERTY OF SKYLOCK INDUSTRIES INCORPORATED. SKYLOCK INDUSTRIES INCORPORATED RESERVES ALL PATENT, PROPRIETARY, DESIGN MANUFACTURING, REPRODUCTION, USE AND SALES RIGHTS THERE TO, AND TO ANY ARTICLE DISCLOSED THEREIN EXCEPT TO THE EXTENT RIGHTS ARE EXPRESSLY GRANTED TO OTHERS. THE FOREGOING DOES NOT APPLY TO VENDOR PROPRIETARY PARTS.

REVISIONS

ZONE	LTR	DESCRIPTION	DATE	APPROVED
	A	REDRAWN	6-12-96	T. C.

NOTES: UNLESS OTHERWISE SPECIFIED.

1. MAT'L: HOUSING: 6061-T6 ALUM ALLOY, BOLT AND HANDLE: 303 CRES.
2. FINISH: ALUM.: CLEAR ANODIZE, CRES.: PASSIVATE.
3. BOLT IS SPRING LOADED TO THE EXTENDED POSITION.

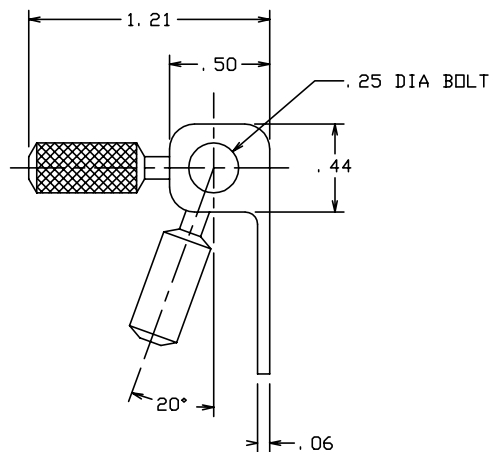
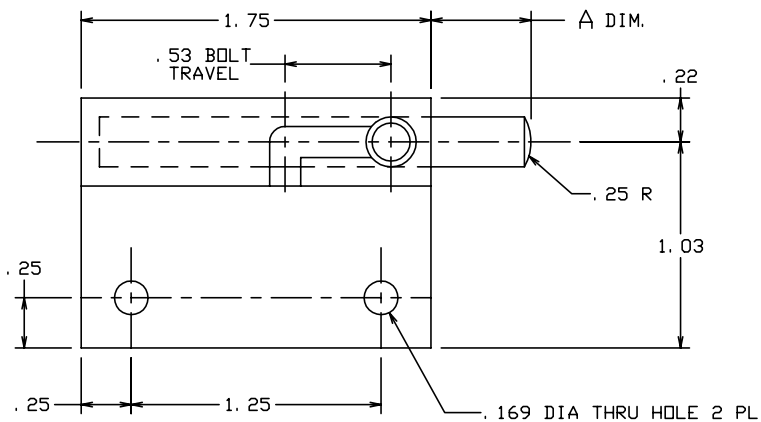

.75	-3	HINGE ASSY	R. H. (SHOWN)		
.50	-2	HINGE ASSY	L. H. (OPP.)		
.50	-1	HINGE ASSY	R. H. (SHOWN)		
A	PART NO.	DESCRIPTION	MATERIAL	SIZE SPECIFICATION	ITEM NO.

PARTS LIST

UNLESS OTHERWISE SPECIFIED	DRAWN BY S. CSIK	6-7-89	 SKYLOCK INDUSTRIES INCORPORATED MONROVIA CALIFORNIA U. S. A.		
DIMENSIONS ARE IN INCHES	CHECKED				
TOLERANCES ON	ENGINEER		LATCH RELEASE HINGE		
DECIMALS ANGLES DRILLED HOLES	PROJECT				
.X ± .1 ± 0° 30' AND 10387 .XX ± .03 .XXX ± .010	APPROVAL				
DO NOT SCALE THIS DRAWING	APPROVAL				
MATERIAL - FINISH	USED ON	SIZE	CODE IDENT. NO.	DRAWING NO.	REV.
NEXT ASSY		C	51941	20644	A
FINAL ASSY		SCALE	2: 1	VT.	SHEET 1 OF 1

4

3

2

1