

THE INFORMATION AND DESIGN HEREIN WAS ORIGINATED BY AND IS THE PROPERTY OF SKYLOCK INDUSTRIES INCORPORATED. SKYLOCK INDUSTRIES INCORPORATED RESERVES ALL PATENT, PROPRIETARY, DESIGN MANUFACTURING, REPRODUCTION, USE AND SALES RIGHTS THERETO, AND TO ANY ARTICLE DISCLOSED THEREIN EXCEPT TO THE EXTENT RIGHTS ARE EXPRESSLY GRANTED TO OTHERS. THE FOREGOING DOES NOT APPLY TO VENDOR PROPRIETARY PARTS.

REVISIONS				
ZONE	LTR.	DESCRIPTION	DATE	APPROVED
	D	REVISED AND REDRAWN	8.19.92	SC

NOTES: UNLESS OTHERWISE SPECIFIED

1. REMOVE ALL BURRS AND SHARP EDGES
2. MAT'L: BRACKETS, HOOK, RIVETS; 2024-T3/T4 ALUM ALLOY; SPRING; CRES; ALL OTHER COMPONENTS; STEEL
3. FINISH: ALUM; CLEAR ANODIZE; CRES; PASSIVATE; STEEL; CAD PLATE

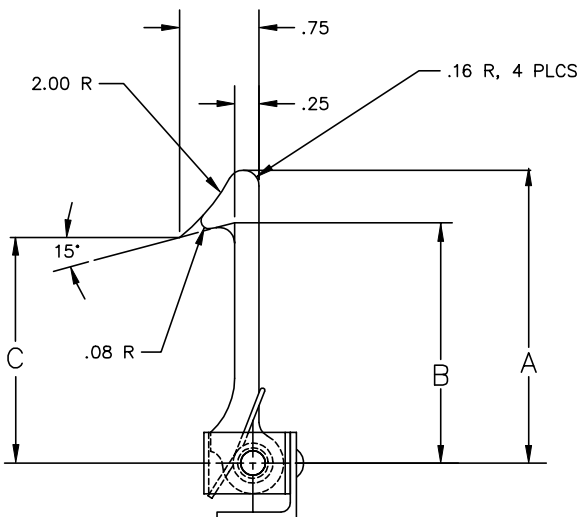

-405 SHOWN
S/A -401 EXCEPT AS SHOWN

DASH NO.	A	B	C
-401	2.06	1.81	1.66
-403	2.31	2.06	1.91
-405	3.00	2.43	2.35

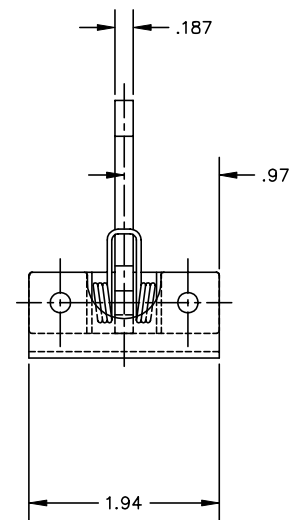
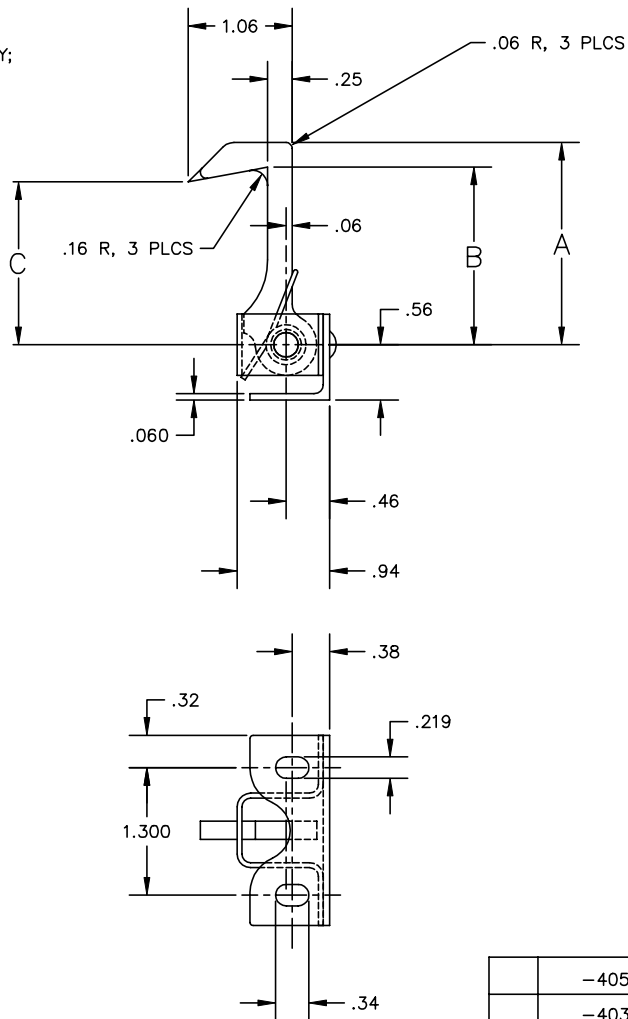

-401 AND -403 SHOWN

	-405	LATCH ASSY		
	-403	LATCH ASSY		
	-401	LATCH ASSY		
QTY. REQ'D	PART / IDENT NO.	DESCRIPTION	MATERIAL / SPECIFICATION	ITEM NO.
UNLESS OTHERWISE SPECIFIED: DIMENSIONS ARE IN INCHES		CONTRACT NO.	 SKYLOCK INDUSTRIES INCORPORATED MONROVIA, CALIFORNIA, USA	
TOLERANCES		CUSTOMER		
DECIMALS .XX ±.03	ANGULAR ± 0 30'	DRAWN BY S. CSIK	DATE	LATCH ASSY, HOOK
DO NOT SCALE DRAWING		CHECK	KEY	
NEXT ASSY	FINAL ASSY	DESIGN ACTIVITY	SIZE C	FSCM NO. 51941
USED ON	ACT WT	CALC WT	DRAWING NO. 20655	REV. D
			SCALE 1/1	RELEASE DATE 8.19.92
			SHEET 1	OF 1

DRAWING NO. SHEET 1 OF 1