

THE INFORMATION AND DESIGN HEREIN WAS ORIGINATED BY AND IS THE PROPERTY OF SKYLOCK INDUSTRIES INCORPORATED. SKYLOCK INDUSTRIES INCORPORATED RESERVES ALL PATENT, PROPRIETARY, DESIGN MANUFACTURING, REPRODUCTION, USE AND SALES RIGHTS THERE TO, AND TO ANY ARTICLE DISCLOSED THEREIN EXCEPT TO THE EXTENT RIGHTS ARE EXPRESSLY GRANTED TO OTHERS. THE FOREGOING DOES NOT APPLY TO VENDOR PROPRIETARY PARTS.

REVISIONS				
ZONE	LTR	DESCRIPTION	DATE	APPROVED
	NC	PRODUCTION RELEASE	9-24-91	T. CSIK
	A	ADDED -3	8-10-93	T. CSIK
	B	ADDED -5 THRU -8	5-26-98	T. CSIK

- NOTES: UNLESS OTHERWISE SPECIFIED.
- REMOVE ALL BURRS AND BREAK SHARP EDGES.
 - MAT'L: HANDLE; ALUM. ALLOY, ALL OTHER PARTS; 300 SERIES CRES.
 - FINISH: HANDLE; CLEAR ANODIZE, CRES PARTS; PASSIVATE.
 - DECORATIVE FINISH: SATIN BUFF HANDLE AND TOP FLANGE OF CASE.
 - BOLT IS DETENTED IN EXTENDED AND RETRACTED POSITIONS.

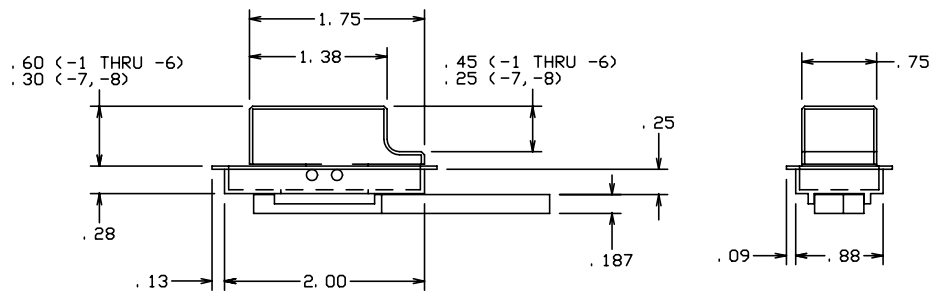
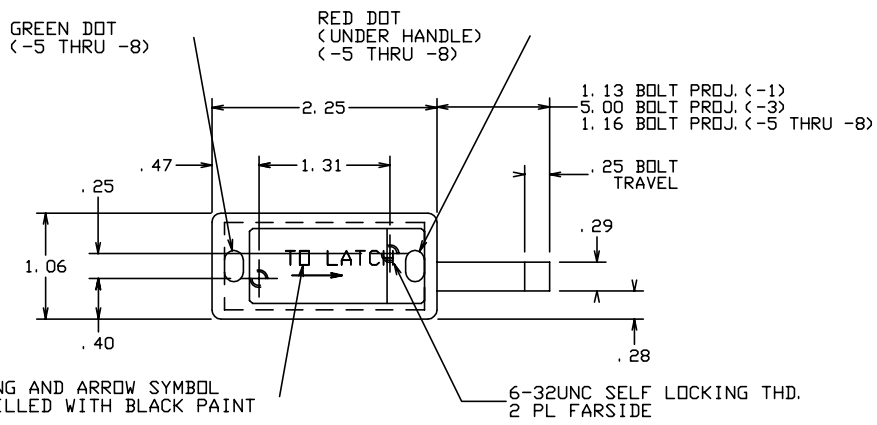

-8	LATCH ASSY	<OPP. -7>	
-7	LATCH ASSY		
-6	LATCH ASSY	<OPP. -5>	
-5	LATCH ASSY		
-3	LATCH ASSY		
-1	LATCH ASSY		
PART NO.	DESCRIPTION	MATERIAL SIZE SPECIFICATION	ITEM NO.

PARTS LIST			
UNLESS OTHERWISE SPECIFIED	DRAWN BY T. CSIK	9-24-91	SKYLOCK INDUSTRIES INCORPORATED MONROVIA CALIFORNIA U. S. A.
DIMENSIONS ARE IN INCHES	CHECKED		
TOLERANCES ON	ENGINEER		
DECIMALS ANGLES DRILLED HOLES	PROJECT		
.X ± .1 ± 0° 30' AND 10387	APPROVAL T. CSIK	9-24-91	LATCH ASSEMBLY
.XX ± .03	APPROVAL		
.XXX ± .010			
DO NOT SCALE THIS DRAWING	USED ON	SIZE	CODE IDENT. NO.
MATERIAL - FINISH		C	51941
NEXT ASSY			20731
FINAL ASSY		SCALE 1:1	REV. B
		VT.	SHEET 1 OF 1