

4

3

2

1

THE INFORMATION AND DESIGN HEREIN WAS ORIGINATED BY AND IS THE PROPERTY OF SKYLOCK INDUSTRIES INCORPORATED. SKYLOCK INDUSTRIES INCORPORATED RESERVES ALL PATENT, PROPRIETARY, DESIGN MANUFACTURING, REPRODUCTION, USE AND SALES RIGHTS THERE TO, AND TO ANY ARTICLE DISCLOSED THEREIN EXCEPT TO THE EXTENT RIGHTS ARE EXPRESSLY GRANTED TO OTHERS. THE FOREGOING DOES NOT APPLY TO VENDOR PROPRIETARY PARTS.

REVISIONS				
ZONE	LTR	DESCRIPTION	DATE	APPROVED
	NC	PRODUCTION RELEASE	9-25-91	T. CSIK
	A	ADDED -2	7-25-94	T. CSIK
	B	ADDED -3/-4	9-7-94	T. CSIK
	C	ADDED -5 THRU -8	2-9-95	T. CSIK
	D	ADDED -9/-10	7-3-95	T. CSIK

NOTES: UNLESS OTHERWISE SPECIFIED.

1. REMOVE ALL BURRS AND BREAK SHARP EDGES.
2. MAT'L: RETAINER, TURN BUTTON, MOUNTING PLATE; ALUM. ALLOY, ALL OTHER PARTS; 300 SERIES CRES. (-1/-2, -5/-6, -9/-10)
TURN BUTTON, MOUNTING PLATE; ALUM. ALLOY, RETAINER AND ALL OTHER PARTS; 300 SERIES CRES. (-3/-4, -7/-8)
3. FINISH: ALUM.; ANODIZE, CRES PARTS; PASSIVATE.
4. DECORATIVE FINISH: RETAINER & TURN BUTTON; BRIGHT BUFF AND CANDY APPLE RED ANODIZE (-1/-2, -5/-6),
TURN BUTTON; BRIGHT BUFF AND CANDY APPLE RED ANODIZE (-3/-4, -7/-8),
RETAINER AND TURN BUTTON; SATIN BRUSH AND CLEAR ANODIZE (-9/-10).
5. STATIC LOAD: 800 LBS. MAX.
6. EXAMPLE PART NO. ; 20734-1-18.50 = "A" @ 18.50".

	-10	RETAINER ASSY	(OPP. -9)	
	-9	RETAINER ASSY	(SHOWN)	
	-8	RETAINER ASSY	(OPP. -7)	
	-7	RETAINER ASSY	(SHOWN)	
	-6	RETAINER ASSY	(OPP. -5)	
	-5	RETAINER ASSY	(SHOWN)	
	-4	RETAINER ASSY	(OPP. -3)	
	-3	RETAINER ASSY	(SHOWN)	
	-2	RETAINER ASSY	(OPP. -1)	
	-1	RETAINER ASSY	(SHOWN)	
	PART NO.	DESCRIPTION	MATERIAL SIZE SPECIFICATION	ITEM NO.

PARTS LIST

UNLESS OTHERWISE SPECIFIED	DRAWN BY T. CSIK	9-25-91	 SKYLOCK INDUSTRIES INCORPORATED MONROVIA CALIFORNIA U. S. A.		
DIMENSIONS ARE IN INCHES	CHECKED				
TOLERANCES ON	ENGINEER				
DECIMALS ANGLES DRILLED HOLES	PROJECT				
.X ± .1 ± 0° 30' AND 10387	APPROVAL T. CSIK	9-25-91	CARRIER RETAINER ASSY		
.XX ± .03	APPROVAL				
.XXX ± .010					
DO NOT SCALE THIS DRAWING					
MATERIAL - FINISH	USED ON	SIZE	CODE IDENT. NO.	DRAWING NO.	REV.
NEXT ASSY		C	51941	20734	D
FINAL ASSY		SCALE	1: 1	WT.	SHEET 1 OF 3

4

3

2

1

THE INFORMATION AND DESIGN HEREIN WAS ORIGINATED BY AND IS THE PROPERTY OF SKYLOCK INDUSTRIES INCORPORATED. SKYLOCK INDUSTRIES INCORPORATED RESERVES ALL PATENT, PROPRIETARY, DESIGN MANUFACTURING, REPRODUCTION, USE AND SALES RIGHTS THERE TO, AND TO ANY ARTICLE DISCLOSED THEREIN EXCEPT TO THE EXTENT RIGHTS ARE EXPRESSLY GRANTED TO OTHERS. THE FOREGOING DOES NOT APPLY TO VENDOR PROPRIETARY PARTS.

REVISIONS				
ZONE	LTR	DESCRIPTION	DATE	APPROVED
		SEE SHT. 1 FOR NOTES		

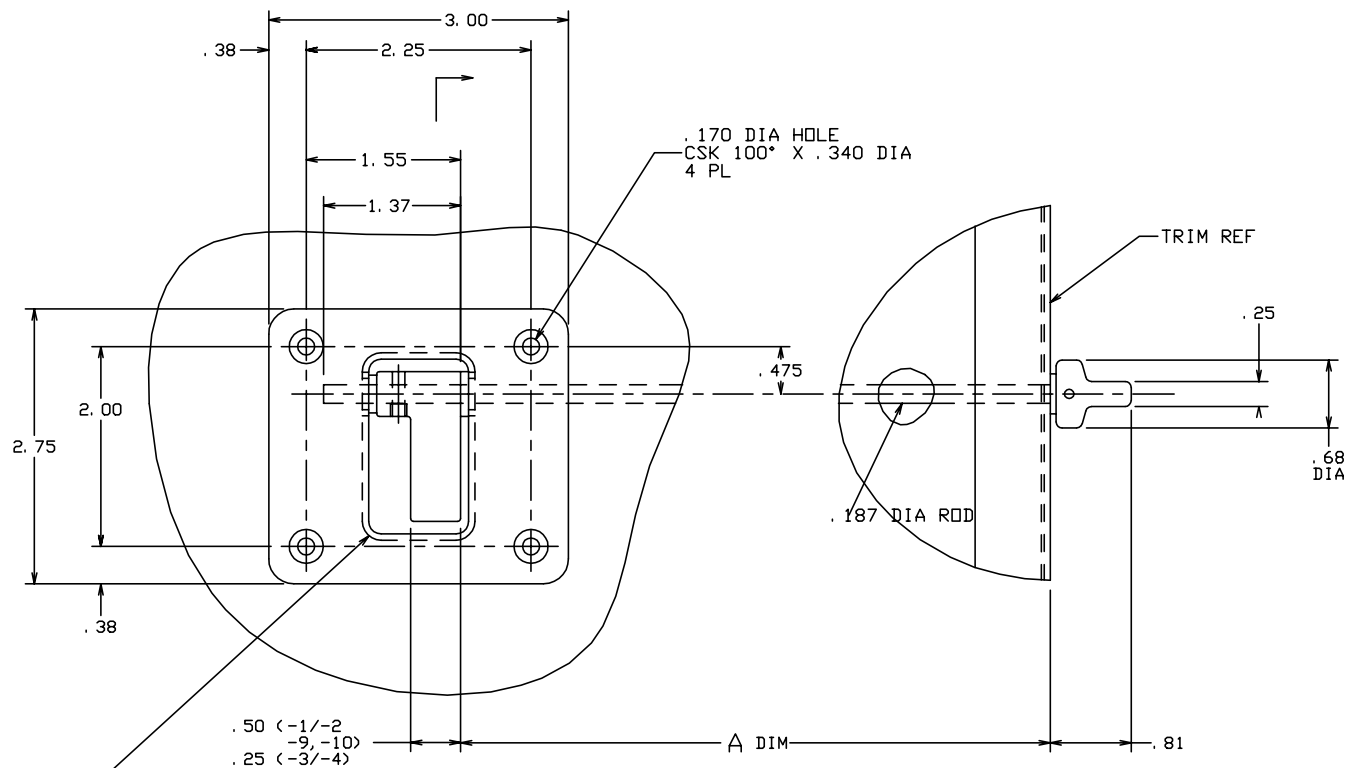
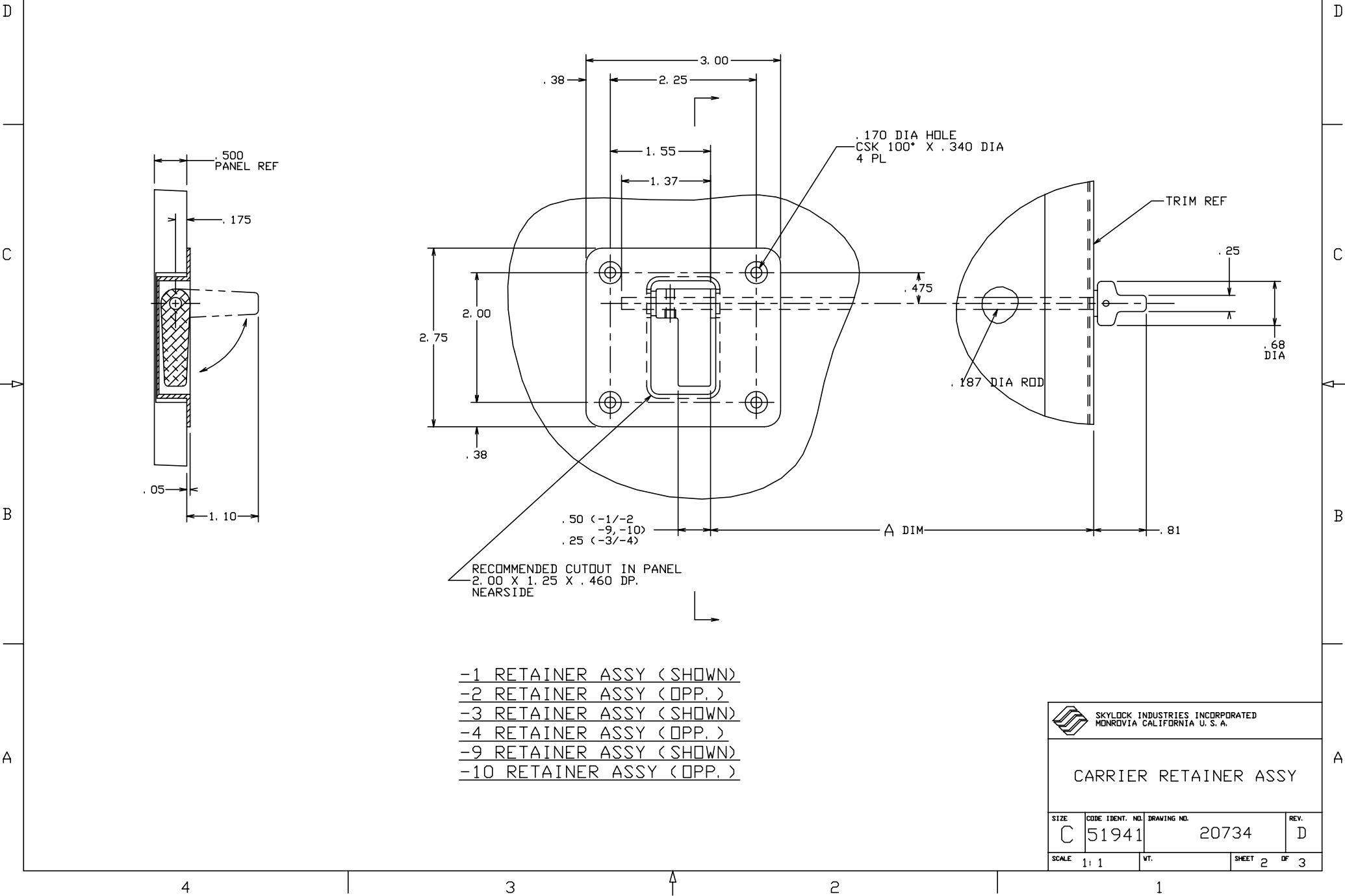

RECOMMENDED CUTOUT IN PANEL
2.00 X 1.25 X .460 DP.
NEARSIDE

- 1 RETAINER ASSY (SHOWN)
- 2 RETAINER ASSY (OPP.)
- 3 RETAINER ASSY (SHOWN)
- 4 RETAINER ASSY (OPP.)
- 9 RETAINER ASSY (SHOWN)
- 10 RETAINER ASSY (OPP.)

SKYLOCK INDUSTRIES INCORPORATED MONROVIA CALIFORNIA U. S. A.			
<h3>CARRIER RETAINER ASSY</h3>			
SIZE	CODE IDENT. NO.	DRAWING NO.	REV.
C	51941	20734	D
SCALE	1: 1	VT.	SHEET 2 OF 3

THE INFORMATION AND DESIGN HEREIN WAS ORIGINATED BY AND IS THE PROPERTY OF SKYLOCK INDUSTRIES INCORPORATED. SKYLOCK INDUSTRIES INCORPORATED RESERVES ALL PATENT, PROPRIETARY, DESIGN MANUFACTURING, REPRODUCTION, USE AND SALES RIGHTS THERE TO, AND TO ANY ARTICLE DISCLOSED THEREIN EXCEPT TO THE EXTENT RIGHTS ARE EXPRESSLY GRANTED TO OTHERS. THE FOREGOING DOES NOT APPLY TO VENDOR PROPRIETARY PARTS.

REVISIONS				
ZONE	LTR	DESCRIPTION	DATE	APPROVED
		SEE SHT. 1 FOR NOTES		

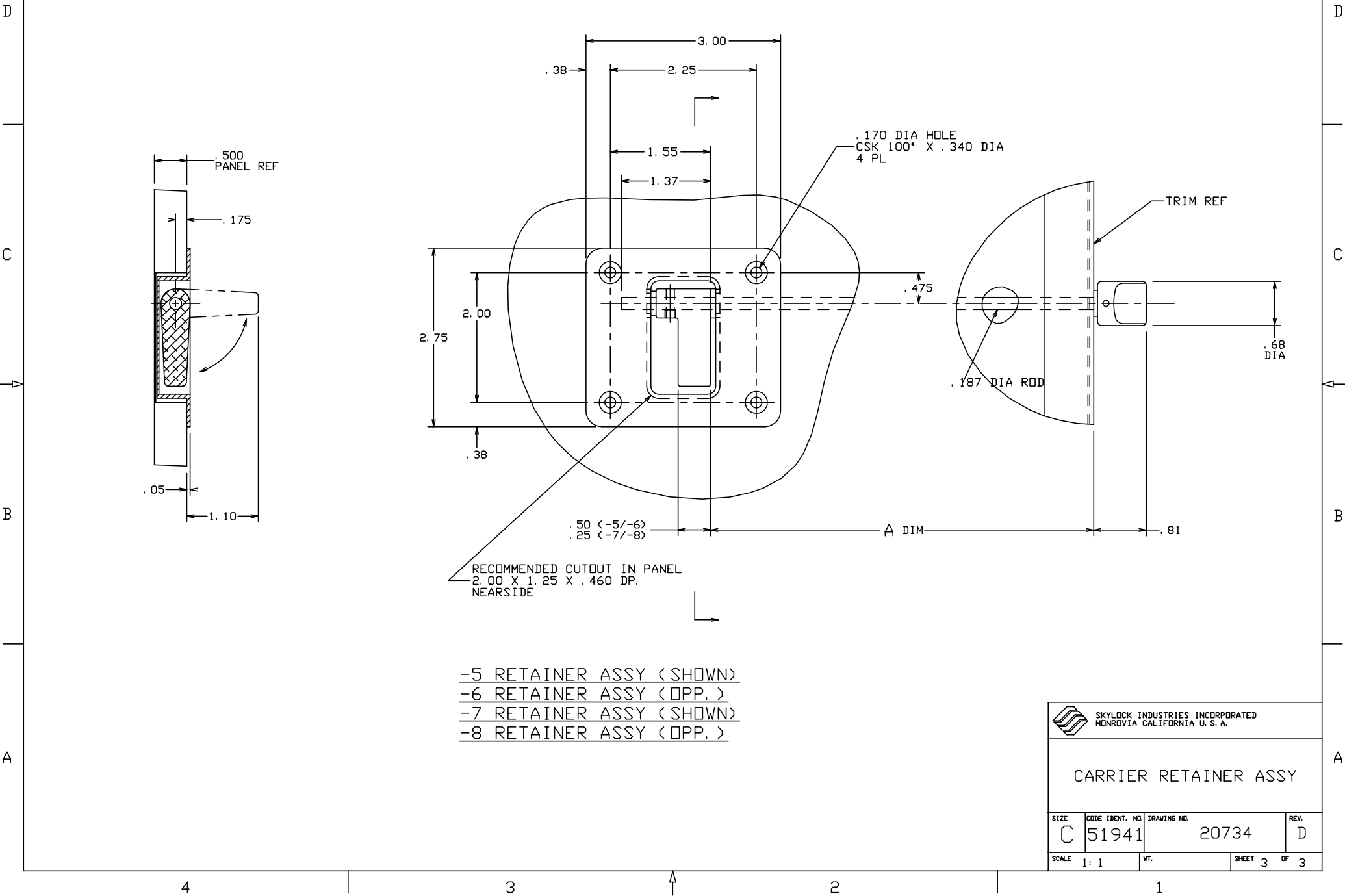

- 5 RETAINER ASSY (SHOWN)
- 6 RETAINER ASSY (DPP.)
- 7 RETAINER ASSY (SHOWN)
- 8 RETAINER ASSY (DPP.)

 SKYLOCK INDUSTRIES INCORPORATED
 MONROVIA CALIFORNIA U. S. A.

CARRIER RETAINER ASSY

SIZE	CODE IDENT. NO.	DRAWING NO.	REV.
C	51941	20734	D
SCALE	1: 1	VT.	SHEET 3 OF 3