

THE INFORMATION AND DESIGN HEREIN WAS ORIGINATED BY AND IS THE PROPERTY OF SKYLOCK INDUSTRIES INCORPORATED. SKYLOCK INDUSTRIES INCORPORATED RESERVES ALL PATENT, PROPRIETARY, DESIGN MANUFACTURING, REPRODUCTION, USE AND SALES RIGHTS THERE TO, AND TO ANY ARTICLE DISCLOSED THEREIN EXCEPT TO THE EXTENT RIGHTS ARE EXPRESSLY GRANTED TO OTHERS. THE FOREGOING DOES NOT APPLY TO VENDOR PROPRIETARY PARTS.

REVISIONS				
ZONE	LTR	DESCRIPTION	DATE	APPROVED
	NC	PRODUCTION RELEASE	1-23-92	T. C.
	A	OBSOLETE -1, ADDED -3 TO REPLACE -1	11-9-94	T. C.
	B	ADDED -5	9-27-96	T. C.
	C	ADDED WHITE BACKGROUND FOR -5	3-14-97	T. C.
	D	ADDED -7	4-3-98	T. C.
	E	REMOVED NOTE 3. WAS. FINISH: PASSIVATE. REVISED DIMS: IS 3.00/2.90 WAS 3.00, IS 3.50/3.40 WAS 3.50, ZN B4 NOTE IS CSK 100° X .280 DIA, WAS DIMPLE 100° X .279 DIA, IS .250/ .200 TYP WAS .250 TYP	6-22-98	T. C.
	F	SEE ECN F	9/10/99	E. W.
	G	SEE ECN G	10/7/99	T. CSIK

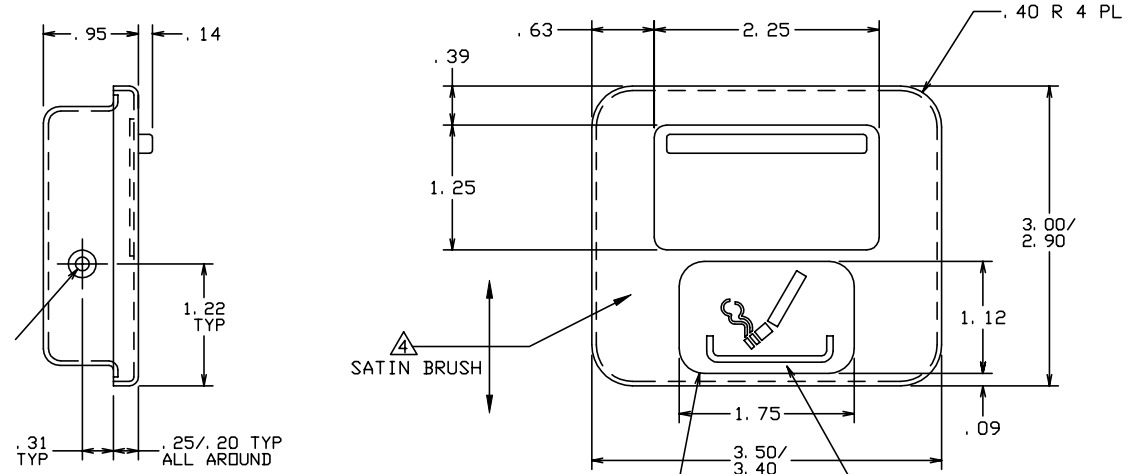

NO. 18 (.172) DIA THRU HOLE
CSK 100° X .280 DIA
NEAR AND FAR SIDE (FROM INSIDE)

△ SATIN BRUSH

-3 ASHTRAY (SHOWN)
-5 ASHTRAY (SHOWN)
-7 ASHTRAY (SHOWN)

BLACK SILKSCREEN SYMBOL (-3)
RED SILKSCREEN SYMBOL (-5)
WHITE SILKSCREEN BACKGROUND (-5 ONLY)
.25 R CORNERS 4 PL

7. APPLICABLE TO FAA-PMA REPLACEMENT OR MODIFICATION PARTS ONLY. PER FAR 45.15, PARTS WILL BE IDENTIFIED WITH:
1. FAA-PMA.
 2. SKYLOCK IND. INC.
 3. PART NO.
 4. AIRCRAFT INSTALLATION ELIGIBILITY.

6. SUGGESTED PANEL CUTOUT: 3.12 W X 2.60 H X .70 DP.
5. OPERATION: ASHTRAY RECEPTACLE IS SPRING CLIP LOADED INTO ASHTRAY RECEIVER AND IS REMOVABLE FOR CLEANING PURPOSES. ASHTRAY DOOR IS SPRING LOADED TO MAINTAIN OPEN OR CLOSED POSITION. LOWER DOOR TO DEPOSIT ASHES, RAISE DOOR TO EXTINGUISH ASHES.

△ DECORATIVE FINISH: REF. SATIN BRUSH DIRECTION NOTED.
3. REMOVED.

2. MAT'L: REF. ALL COMPONENTS; 302/304 CRES, COND. A, PER ASTM-A240, OR EQUIV.

1. REMOVE ALL BURRS AND BREAK SHARP EDGES.

NOTES: UNLESS OTHERWISE SPECIFIED.

	-7	ASHTRAY	(SHOWN, NO SYMBOLOGY)	120747-207
	-5	ASHTRAY	(SHOWN)	120747-205
	-3	ASHTRAY	(REPLACES -1)	120747-203
	-1	OBSOLETE		

QTY REQD	PART NO.	DESCRIPTION	MATERIAL	SIZE	SPECIFICATION	MAKE FROM	
PARTS LIST							
UNLESS OTHERWISE SPECIFIED		DRAWN BY	T. CSIK	1-3-92	SKYLOCK INDUSTRIES INCORPORATED MONROVIA CALIFORNIA U. S. A.		
DIMENSIONS ARE IN INCHES		CHECKED	E. WELSH	8/27/99			
TOLERANCES ON		ENGINEER	E. WELSH	9/10/99			
DECIMALS ANGLES DRILLED HOLES		QC	J. VIVIRITO	9/17/99			
.X ± .1 ± 0° 30' AND 10387		WFG	P. MATSUOKA	9/16/99	ASHTRAY		
.XX ± .03							
.XXX ± .010							
DO NOT SCALE THIS DRAWING							
MATERIAL - FINISH		USED ON		SIZE	CODE IDENT. NO.	DRAWING NO.	
NEXT ASSY				C	51941	20747	
MANUFACTURE IN ACCORDANCE WITH SKYLOCK IND. INC., QUALITY CONTROL MANUAL QC.001				SCALE	2: 1	VT.	SHEET 1 OF 1