

THE INFORMATION AND DESIGN HEREIN WAS ORIGINATED BY AND IS THE PROPERTY OF SKYLOCK INDUSTRIES INCORPORATED. SKYLOCK INDUSTRIES INCORPORATED RESERVES ALL PATENT, PROPRIETARY, DESIGN, MANUFACTURING, REPRODUCTION, USE AND SALES RIGHTS THEREON, AND TO ANY ARTICLE DISCLOSED THEREIN EXCEPT TO THE EXTENT RIGHTS ARE EXPRESSLY GRANTED TO OTHERS. THE FOREGOING DOES NOT APPLY TO VENDOR PROPRIETARY PARTS.

REVISIONS				
ZONE	LTR	DESCRIPTION	DATE	APPROVED
	NC	PRODUCTION RELEASE	3-9-92	T. CSIK

NOTES: UNLESS OTHERWISE SPECIFIED.

1. REMOVE ALL BURRS AND BREAK SHARP EDGES.
2. MAT'L: RETAINER; ALUM. ALLOY,  
ALL OTHER PARTS: 300 SERIES CRES.
3. FINISH: ALUM.; ANODIZE. CRES PARTS; PASSIVATE.
4. DECORATIVE FINISH: RETAINER; BRIGHT BUFF  
AND CANDY APPLE RED ANODIZE.
5. RETAINER IS DETENTED EACH 90°.  
ROTATION 90° LEFT OR RIGHT HAND.

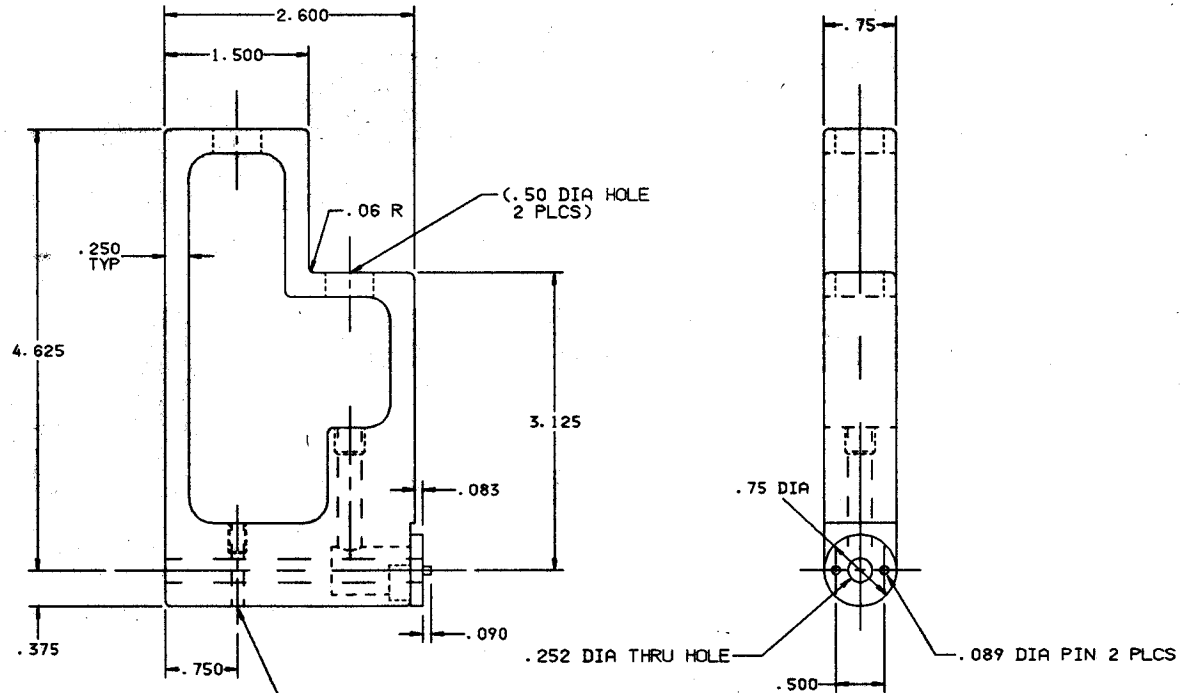

THREADED PIN WITH HEX SOCKET HEAD  
DRILL .125 DIA HOLE THRU TUBE AT INSTALLATION

-401		RETAINER ASSY			
PART NO.	DESCRIPTION	MATERIAL SIZE SPECIFICATION		ITEM NO.	
PARTS LIST					
UNLESS OTHERWISE SPECIFIED		DRAWN BY T. CSIK		3-9-92	
DIMENSIONS ARE IN INCHES		CHECKED		SKYLOCK INDUSTRIES INCORPORATED MONROVIA CALIFORNIA U.S.A.	
TOLERANCES ON		ENGINEER			
DECIMALS ANGLES DRILLED HOLES		PROJECT			
.X .X .1 ± 0° 30' AND 10587		APPROVAL T. CSIK			
.XXX .010		APPROVAL		3-9-92	
DO NOT SCALE THIS DRAWING					
MATERIAL - FINISH		USED ON		SIZE	
NEXT ASSY				C 51941	
FINL ASSY				20759	
				REV. NC	
		SCALE 1:1		SHEET 1 OF 1	