

THE INFORMATION AND DESIGN HEREIN WAS ORIGINATED BY AND IS THE PROPERTY OF SKYLOCK INDUSTRIES INCORPORATED. SKYLOCK INDUSTRIES INCORPORATED RESERVES ALL PATENT, PROPRIETARY, DESIGN MANUFACTURING, REPRODUCTION, USE AND SALES RIGHTS THERE TO, AND TO ANY ARTICLE DISCLOSED THEREIN EXCEPT TO THE EXTENT RIGHTS ARE EXPRESSLY GRANTED TO OTHERS. THE FOREGOING DOES NOT APPLY TO VENDOR PROPRIETARY PARTS.

REVISIONS				
ZONE	LTR	DESCRIPTION	DATE	APPROVED
	NC	PRODUCTION RELEASE	4-13-92	T. CSIK
	A	EXTENDED HANDLE .25"	11-2-92	T. CSIK
	B	ADDED -403, SHT. 2	3-15-94	T. CSIK

- NOTES: UNLESS OTHERWISE SPECIFIED.
- REMOVE ALL BURRS AND BREAK SHARP EDGES.
 - MAT'L: HOUSING & HANDLE; 6061-T6 ALUM. ALLOY, ALL OTHERS COMP'S; 300 SERIES CRES.
 - FINISH: ALUM.; SATIN BRUSH AND CLEAR ANODIZE, CRES; PASSIVATE.
 - RED DOT IS VISIBLE WHEN BOLT IS RETRACTED.
 - GREEN DOT IS VISIBLE WHEN BOLT IS EXTENDED.

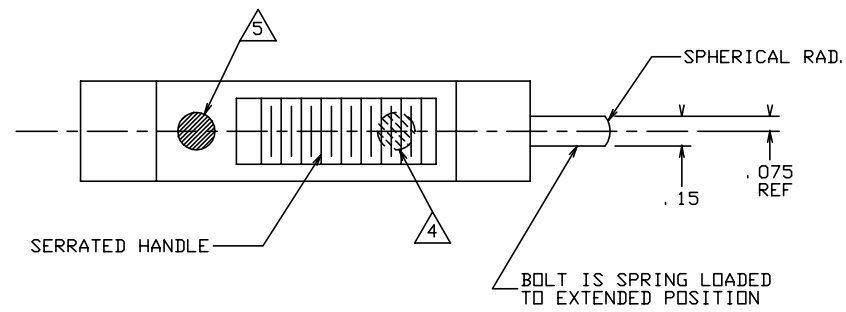
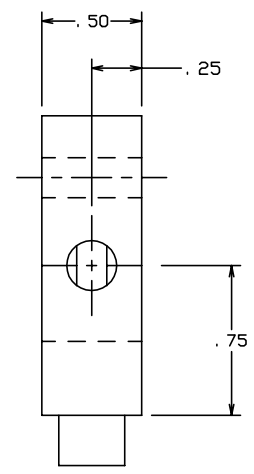
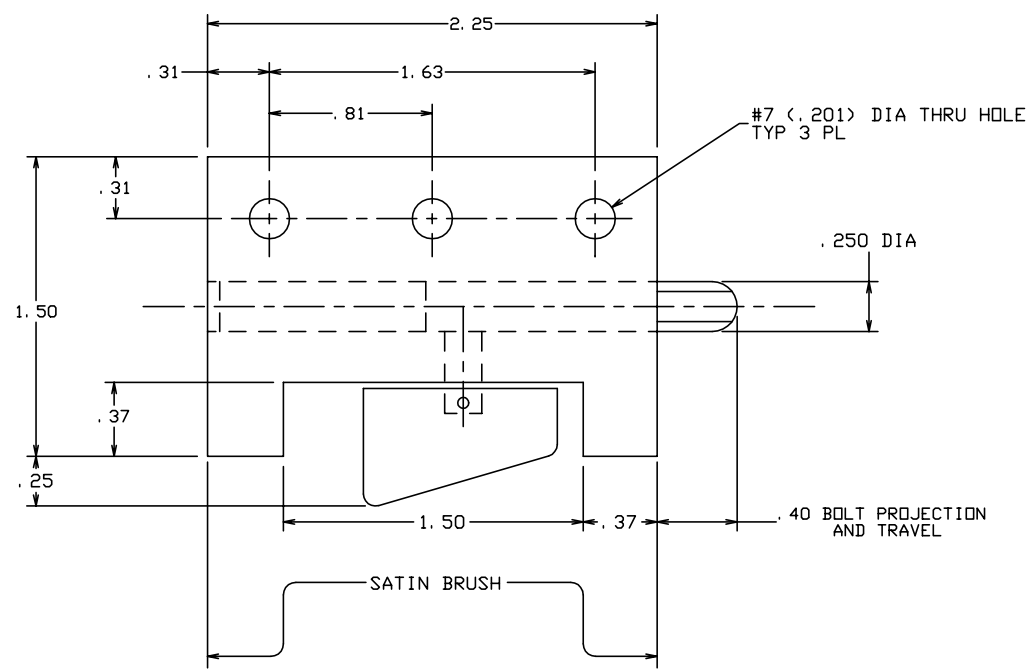

-401 LATCH ASSY

	-403	LATCH ASSY	(SHT. 2)	
	-401	LATCH ASSY		
PART NO.	DESCRIPTION	MATERIAL	SIZE	SPECIFICATION
PARTS LIST				
UNLESS OTHERWISE SPECIFIED	DRAWN BY T. CSIK	4-6-92	SKYLOCK INDUSTRIES INCORPORATED MONROVIA CALIFORNIA U. S. A.	
DIMENSIONS ARE IN INCHES	CHECKED		LATCH ASSY-P/O TABLE	
TOLERANCES ON	ENGINEER			
DECIMALS ANGLES DRILLED HOLES	PROJECT			
.X ± .1 ± 0° 30' AND 10387 .XX ± .03 .XXX ± .010	APPROVAL T. CSIK	4-6-92		
DO NOT SCALE THIS DRAWING	APPROVAL			
MATERIAL - FINISH	USED ON	SIZE	CODE IDENT. NO.	DRAWING NO.
NEXT ASSY		C	51941	20767
FINAL ASSY		SCALE	1:1	VT.
				SHEET 1 OF 2

THE INFORMATION AND DESIGN HEREIN WAS ORIGINATED BY AND IS THE PROPERTY OF SKYLOCK INDUSTRIES INCORPORATED. SKYLOCK INDUSTRIES INCORPORATED RESERVES ALL PATENT, PROPRIETARY, DESIGN MANUFACTURING, REPRODUCTION, USE AND SALES RIGHTS THERE TO, AND TO ANY ARTICLE DISCLOSED THEREIN EXCEPT TO THE EXTENT RIGHTS ARE EXPRESSLY GRANTED TO OTHERS. THE FOREGOING DOES NOT APPLY TO VENDOR PROPRIETARY PARTS.

REVISIONS				
ZONE	LTR	DESCRIPTION	DATE	APPROVED
		SEE SHT. 1		

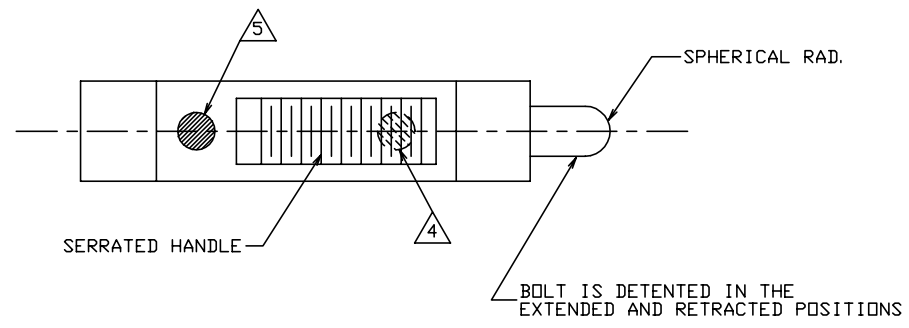
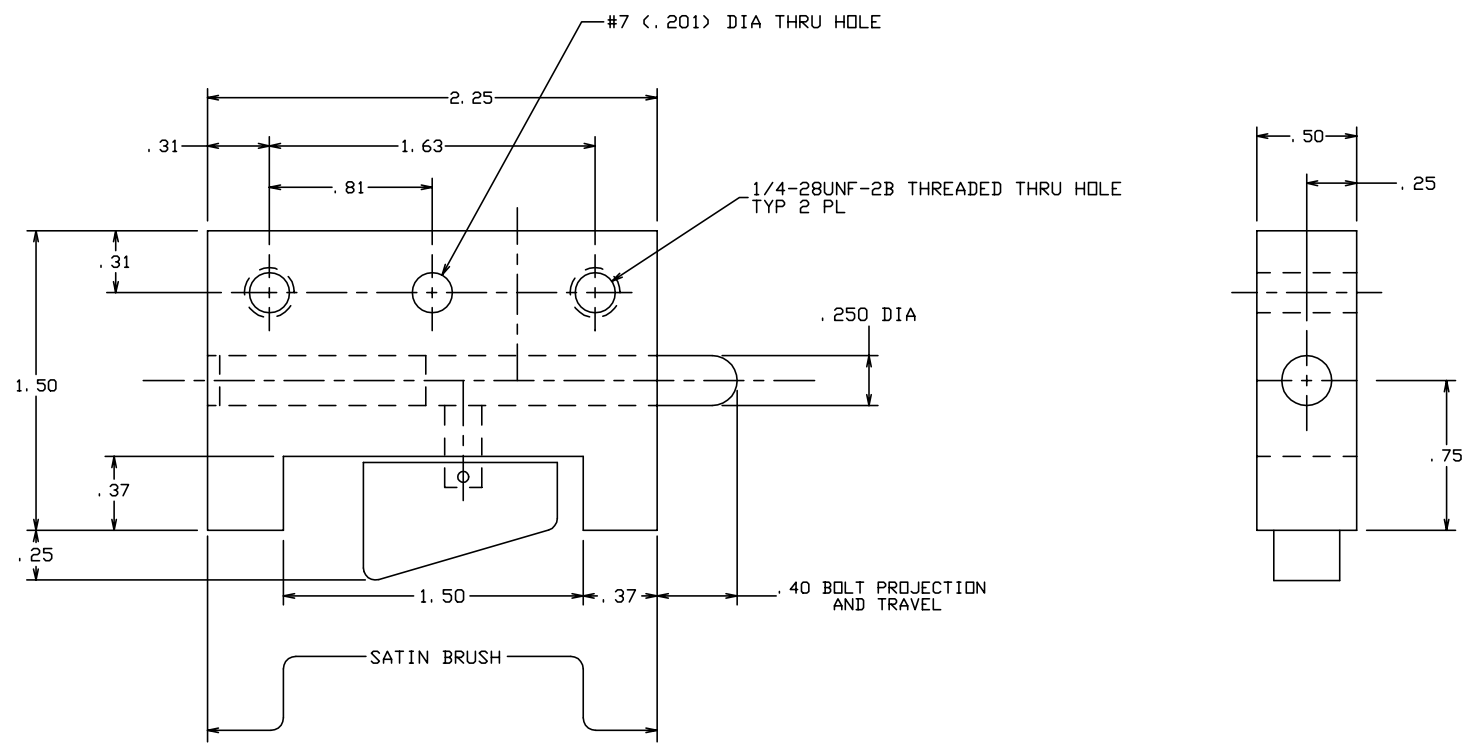

-403 LATCH ASSY

SKYLOCK INDUSTRIES INCORPORATED
MONROVIA CALIFORNIA U. S. A.

LATCH ASSY-P/O TABLE

SIZE C	CODE IDENT. NO. 51941	DRAWING NO. 20767	REV. B
SCALE 1: 1	VT.	SHEET 2	OF 2