

THE INFORMATION AND DESIGN HEREIN WAS ORIGINATED BY AND IS THE PROPERTY OF SKYLOCK INDUSTRIES INCORPORATED. SKYLOCK INDUSTRIES INCORPORATED RESERVES ALL PATENT, PROPRIETARY, DESIGN MANUFACTURING, REPRODUCTION, USE AND SALES RIGHTS THERE TO, AND TO ANY ARTICLE DISCLOSED THEREIN EXCEPT TO THE EXTENT RIGHTS ARE EXPRESSLY GRANTED TO OTHERS. THE FOREGOING DOES NOT APPLY TO VENDOR PROPRIETARY PARTS.

REVISIONS				
ZONE	LTR	DESCRIPTION	DATE	APPROVED
	NC	PRODUCTION RELEASE	8-5-92	T. CSIK

- NOTES: UNLESS OTHERWISE SPECIFIED.
1. REMOVE ALL BURRS AND BREAK SHARP EDGES.
 2. MAT'L: HOUSING; ALUM. ALLOY, BOLT; NYLON
 3. FINISH: ALUM.; CLEAR ANODIZE.
 4. BOLT IS SPRING LOADED TO THE ENGAGED POSITION

#6-32 THREADED HOLE
SELF LOCKING
TYP 2 PL

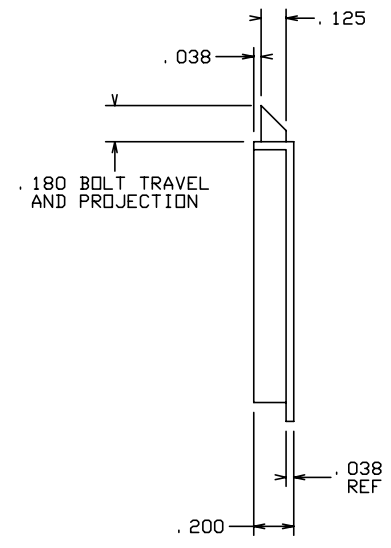
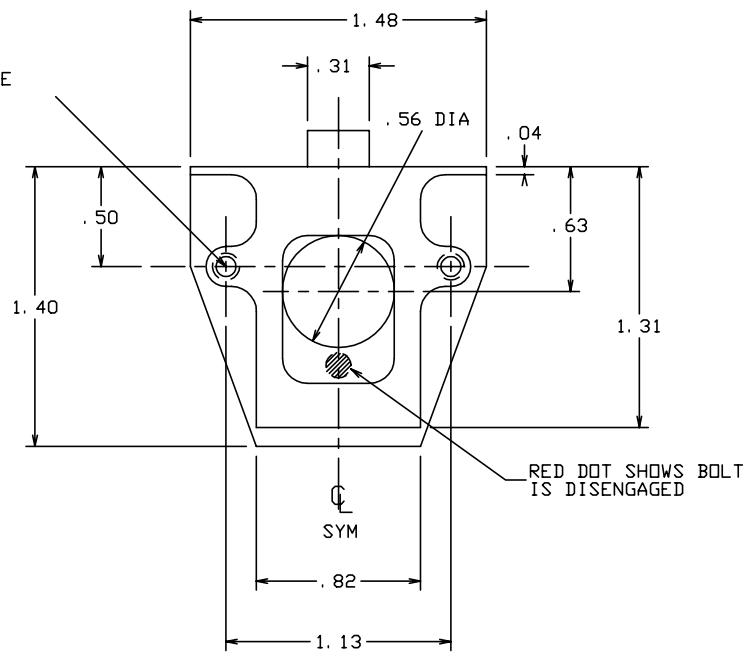

RED DOT SHOWS BOLT IS DISENGAGED

-1		LATCH ASSY					
QTY REQD	PART NO.	DESCRIPTION	MATERIAL	SIZE	SPECIFICATION	ITEM NO.	
PARTS LIST							
UNLESS OTHERWISE SPECIFIED		DRAWN BY	T. CSIK	8-4-92	 SKYLOCK INDUSTRIES INCORPORATED MONROVIA CALIFORNIA U. S. A.		
DIMENSIONS ARE IN INCHES		CHECKED					
TOLERANCES ON		ENGINEER					
DECIMALS ANGLES DRILLED HOLES		PROJECT					
.X ± .1 ± 0° 30' AND 10387		APPROVAL	T. CSIK	8-4-92	LATCH ASSY- FINGER PULL		
.XX ± .03		APPROVAL					
.XXX ± .010		APPROVAL					
DO NOT SCALE THIS DRAWING		APPROVAL					
MATERIAL - FINISH		USED ON		SIZE	CODE IDENT. NO.	DRAWING NO.	REV.
NEXT ASSY				C	51941	20782	NC
FINAL ASSY				SCALE	1: 1	VT.	SHEET 1 OF 1