

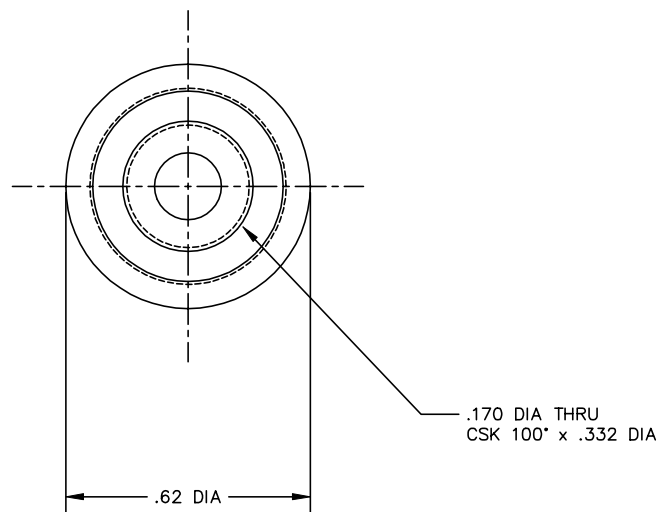
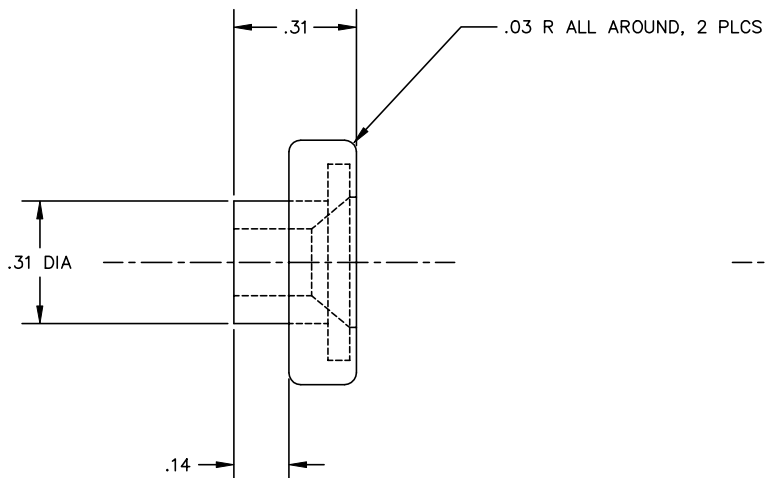

THE INFORMATION AND DESIGN HEREIN WAS ORIGINATED BY AND IS THE PROPERTY OF SKYLOCK INDUSTRIES INCORPORATED. SKYLOCK INDUSTRIES INCORPORATED RESERVES ALL PATENT, PROPRIETARY, DESIGN MANUFACTURING, REPRODUCTION, USE AND SALES RIGHTS THEREON, AND TO ANY ARTICLE DISCLOSED THEREIN EXCEPT TO THE EXTENT RIGHTS ARE EXPRESSLY GRANTED TO OTHERS. THE FOREGOING DOES NOT APPLY TO VENDOR PROPRIETARY PARTS.

REVISIONS				
ZONE	LTR.	DESCRIPTION	DATE	APPROVED
	NC	PRODUCTION RELEASE	8.18.92	SC

NOTES: UNLESS OTHERWISE SPECIFIED

1. REMOVE ALL BURRS AND SHARP EDGES
2. MAT'L: STANDOFF: 300 SERIES CRES; ROLLER; NYLON 6/6
3. FINISH: CRES; CLEAN AND PASSIVATE



-401		ROLLER ASSY			
QTY. REQ'D	PART / IDENT NO.	DESCRIPTION	MATERIAL / SPECIFICATION		ITEM NO.
UNLESS OTHERWISE SPECIFIED: DIMENSIONS ARE IN INCHES		CONTRACT NO.		 <b>SKYLOCK INDUSTRIES INCORPORATED</b> MONROVIA, CALIFORNIA, USA	
TOLERANCES DECIMALS .XX ±.03 .XXX ±.010 DO NOT SCALE DRAWING		CUSTOMER DRAWN BY S. CSIK CHECK DATE			
NEXT ASSY	FINAL ASSY	DESIGN		<b>ROLLER ASSY</b>	
USED ON		DESIGN ACTIVITY			
FINISH	ACT WT	CALC WT	SIZE C	FSCM NO. 51941	DRAWING NO. 20783
			SCALE 4/1	RELEASE DATE 8.18.92	REV. NC
			SHEET 1 OF 1		

DRAWING NO.

SHEET OF

A