

THE INFORMATION AND DESIGN HEREIN WAS ORIGINATED BY AND IS THE PROPERTY OF SKYLOCK INDUSTRIES INCORPORATED. SKYLOCK INDUSTRIES INCORPORATED RESERVES ALL PATENT, PROPRIETARY, DESIGN MANUFACTURING, REPRODUCTION, USE AND SALES RIGHTS THERE TO, AND TO ANY ARTICLE DISCLOSED THEREIN EXCEPT TO THE EXTENT RIGHTS ARE EXPRESSLY GRANTED TO OTHERS. THE FOREGOING DOES NOT APPLY TO VENDOR PROPRIETARY PARTS.

| REVISIONS | | | | |
|-----------|-----|-----------------------------------|----------|----------|
| ZONE | LTR | DESCRIPTION | DATE | APPROVED |
| | NC | PRODUCTION RELEASE | 9-4-92 | T. CSIK |
| | A | DIM. .132 WAS .092 | 10-16-92 | T. CSIK |
| | B | ADDED -403, DIM. WAS .88 DIA THRU | 3-8-93 | T. CSIK |
| | C | -403 REVISED AND REDRAWN | 3-10-93 | T. CSIK |
| | D | -403: ADDED .28 R CORNERS | 3-12-93 | T. CSIK |

- NOTES: UNLESS OTHERWISE SPECIFIED.
1. REMOVE ALL BURRS AND BREAK SHARP EDGES.
 2. MAT'L: CASE; ALUM. ALLOY, BOLT; CRES.
 3. FINISH: CASE; CLEAR ANODIZE, BOLT; PASSIVATE.
 4. BOLT IS SPRING LOADED TO THE ENGAGED POSITION.

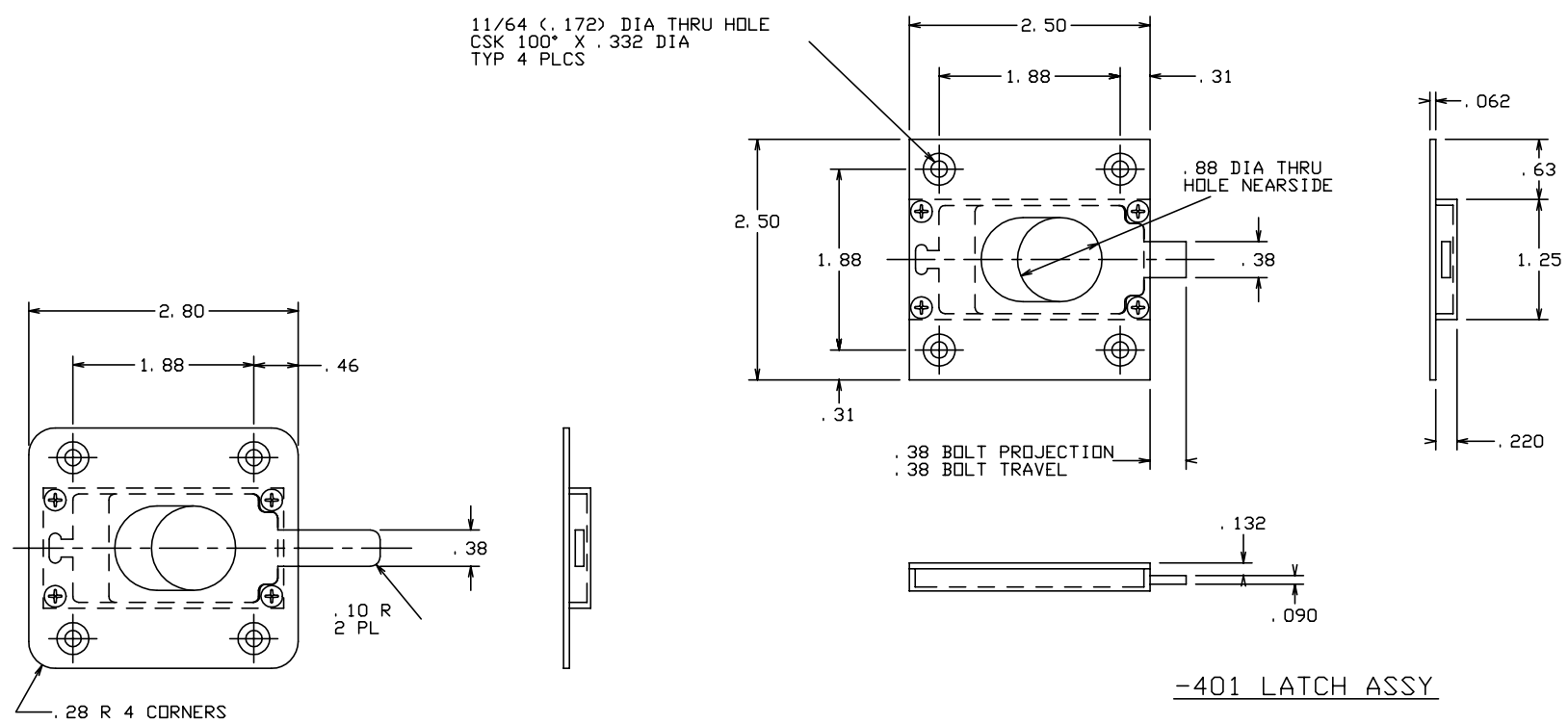

| | -403 | LATCH ASSY | | | | |
|-------------------------------|----------|-------------|----------|--------|---|--------------|
| | -401 | LATCH ASSY | | | | |
| QTY REQD | PART NO. | DESCRIPTION | MATERIAL | SIZE | SPECIFICATION | ITEM NO. |
| PARTS LIST | | | | | | |
| UNLESS OTHERWISE SPECIFIED | | DRAWN BY | T. CSIK | 9-4-92 | SKYLOCK INDUSTRIES INCORPORATED MONROVIA CALIFORNIA U. S. A. | |
| DIMENSIONS ARE IN INCHES | | CHECKED | | | | |
| TOLERANCES ON | | ENGINEER | | | | |
| DECIMALS ANGLES DRILLED HOLES | | PROJECT | | | | |
| .X ± .1 ± 0° 30' AND 10387 | | APPROVAL | T. CSIK | 9-4-92 | LATCH ASSY | |
| .XX ± .03 .XXX ± .010 | | APPROVAL | | | | |
| DO NOT SCALE THIS DRAWING | | | USED ON | SIZE | CODE IDENT. NO. | DRAWING NO. |
| MATERIAL - FINISH | | | | C | 51941 | 20789 |
| NEXT ASSY X | | | | | | D |
| FINAL ASSY X | | | | SCALE | 2:1 | WT. |
| | | | | | | SHEET 1 OF 1 |