

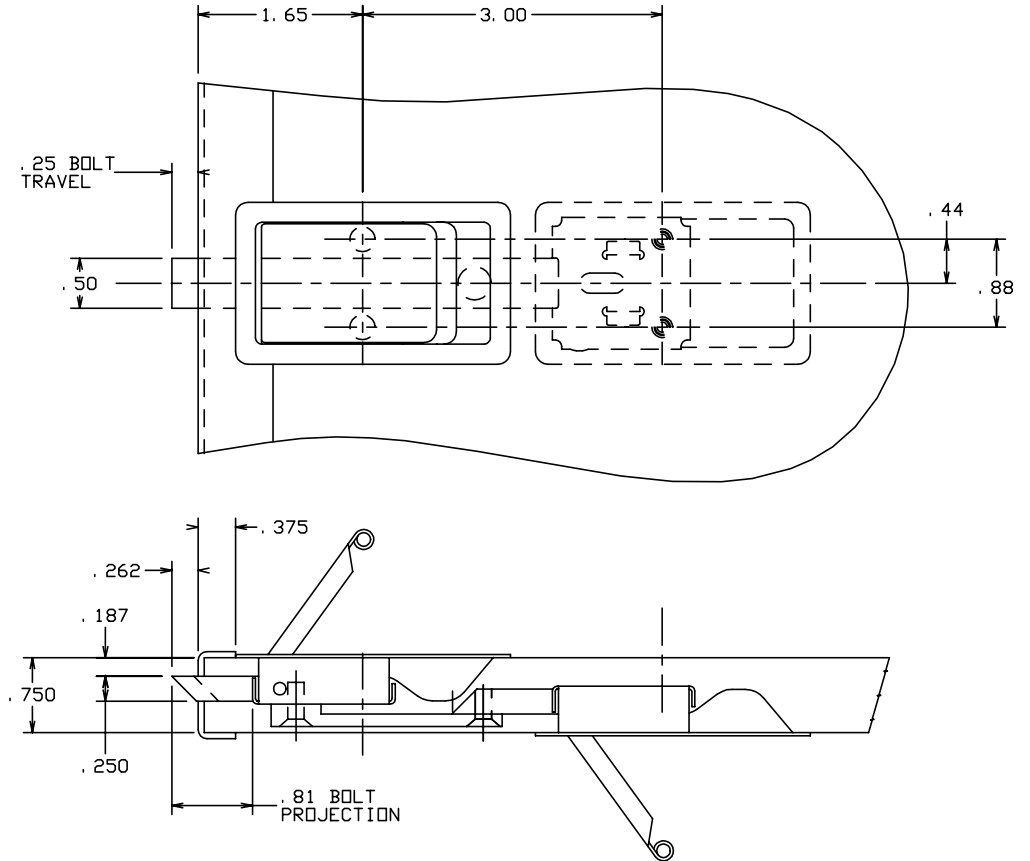

THE INFORMATION AND DESIGN HEREIN WAS ORIGINATED BY AND IS THE PROPERTY OF SKYLOCK INDUSTRIES INCORPORATED. SKYLOCK INDUSTRIES INCORPORATED RESERVES ALL PATENT, PROPRIETARY, DESIGN MANUFACTURING, REPRODUCTION, USE AND SALES RIGHTS THERE TO, AND TO ANY ARTICLE DISCLOSED THEREIN EXCEPT TO THE EXTENT RIGHTS ARE EXPRESSLY GRANTED TO OTHERS. THE FOREGOING DOES NOT APPLY TO VENDOR PROPRIETARY PARTS.

REVISIONS				
ZONE	LTR	DESCRIPTION	DATE	APPROVED
	NC	PRODUCTION RELEASE	9-14-92	T. CSIK

NOTES: UNLESS OTHERWISE SPECIFIED,

1. REMOVE ALL BURRS AND BREAK SHARP EDGES.
2. MAT'L: ALL COMP'S: 300 SERIES CRES.
3. FINISH: PASSIVATE.
4. DECORATIVE FINISH: SATIN BUFF TOP OF CASE AND HANDLE.
5. STATIC LOAD: 600 LBS. MAX.
6. BOLT IS SPRING LOADED AND ALWAYS FREE TO LATCH.
7. HANDLE IS SPRING LOADED OPEN WHEN BOLT IS NOT PROPERLY ENGAGED.



-401		LATCH ASSY		
PART NO.	DESCRIPTION	MATERIAL	SIZE SPECIFICATION	ITEM NO.
PARTS LIST				
UNLESS OTHERWISE SPECIFIED		DRAWN BY	T. CSIK	9-14-92
DIMENSIONS ARE IN INCHES		CHECKED		
TOLERANCES ON		ENGINEER		
DECIMALS ANGLES DRILLED HOLES		PROJECT		
.X ± .1 ± 0° 30' AND 10387		APPROVAL	T. CSIK	9-14-92
.XX ± .03		APPROVAL		
.XXX ± .010		APPROVAL		
DO NOT SCALE THIS DRAWING		 SKYLOCK INDUSTRIES INCORPORATED MONROVIA CALIFORNIA U. S. A.		
MATERIAL - FINISH				
NEXT ASSY	USED ON	SIZE	CODE IDENT. NO.	DRAWING NO.
		C	51941	20793
FINAL ASSY		SCALE	1: 1	WT.
				SHEET 1 OF 1