

4

3

2

1

THE INFORMATION AND DESIGN HEREIN WAS ORIGINATED BY AND IS THE PROPERTY OF SKYLOCK INDUSTRIES INCORPORATED. SKYLOCK INDUSTRIES INCORPORATED RESERVES ALL PATENT, PROPRIETARY, DESIGN MANUFACTURING, REPRODUCTION, USE AND SALES RIGHTS THERE TO, AND TO ANY ARTICLE DISCLOSED THEREIN EXCEPT TO THE EXTENT RIGHTS ARE EXPRESSLY GRANTED TO OTHERS. THE FOREGOING DOES NOT APPLY TO VENDOR PROPRIETARY PARTS.

REVISIONS				
ZONE	LTR	DESCRIPTION	DATE	APPROVED
	NC	PRODUCTION RELEASE	10-19-92	T. C.

- NOTES: UNLESS OTHERWISE SPECIFIED.
- MAT'L: ALL COMPS; 300 CRES.
 - FINISH: CLEAN AND PASSIVATE.
 - DECORATIVE FINISH: SATIN BUFF.
 - STATIC LOAD 600 LBS.
 - BOLT IS SPRING LOADED AND ALWAYS FREE TO LATCH.
- △ SPRING TO RETURN FLAP TO CLOSED POSITION REGARDLESS OF BOLT POSITION.
- △ SPRING TO HOLD FLAP OPEN WHEN BOLT IS NOT PROPERLY ENGAGED.

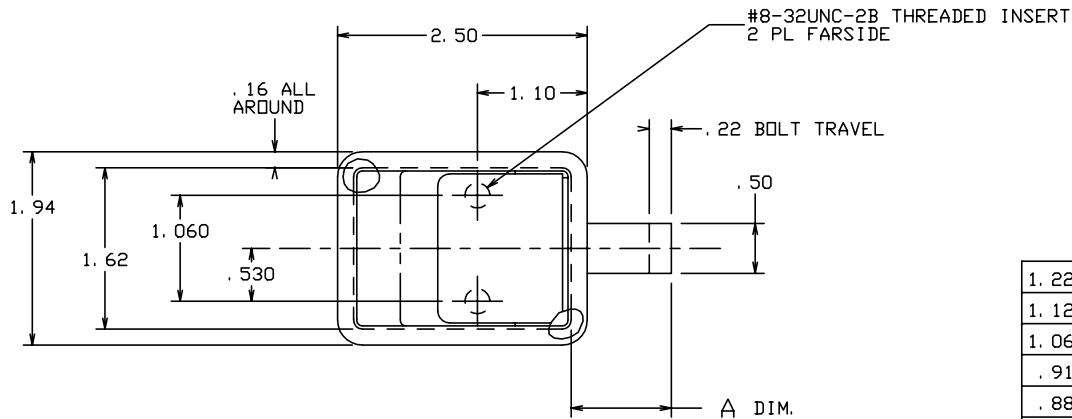

SAMPLE PART NO: 20798-3-9

FLAP SPRING LOADED CLOSED

1.06 BOLT PROJECTION

1.22	-13	LATCH		
1.12	-11	LATCH		
1.06	-9	LATCH		
.91	-7	LATCH		
.88	-5	LATCH		
.81	-3	LATCH		
.69	-1	LATCH		
A DIM	PART NO.	DESCRIPTION	MATERIAL SIZE SPECIFICATION	ITEM NO.
PARTS LIST				
SECONDARY DASH NUMBER				

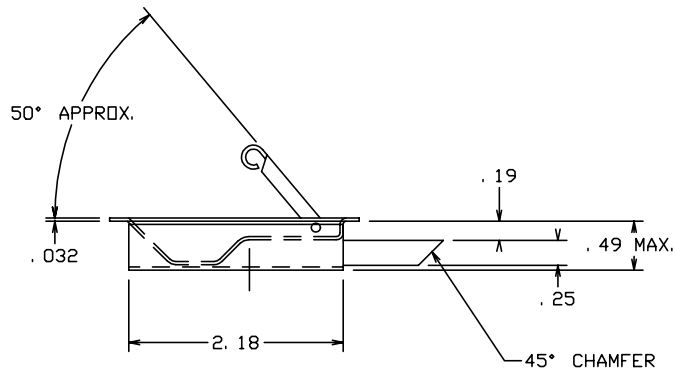

	-5	LATCH	FLAP SPRING OPEN	△
	-3	LATCH	FLAP SPRING CLOSED	△
	-1	LATCH	NO FLAP SPRING	
PART NO.	DESCRIPTION	MATERIAL SIZE SPECIFICATION	ITEM NO.	

PRIMARY DASH NUMBER				
UNLESS OTHERWISE SPECIFIED	DRAWN BY T. CSIK	10-19-92	 SKYLOCK INDUSTRIES INCORPORATED MONROVIA CALIFORNIA U. S. A.	
DIMENSIONS ARE IN INCHES	CHECKED		LATCH ASSY - SLAM	
TOLERANCES ON	ENGINEER			
DECIMALS ANGLES DRILLED HOLES	PROJECT			
.X ± .1 ± 0° 30' AND 10367	APPROVAL T. CSIK	10-19-92		
.XX ± .03	APPROVAL			
.XXX ± .010				
DO NOT SCALE THIS DRAWING				
MATERIAL - FINISH	USED ON	SIZE	CODE IDENT. NO.	DRAWING NO.
		C	51941	20798
NEXT ASSY				REV. NC
FINAL ASSY		SCALE 1:1	WT.	SHEET 1 OF 1

4

3

2

1