

THE INFORMATION AND DESIGN HEREIN WAS ORIGINATED BY AND IS THE PROPERTY OF SKYLOCK INDUSTRIES INCORPORATED. SKYLOCK INDUSTRIES INCORPORATED RESERVES ALL PATENT, PROPRIETARY, DESIGN MANUFACTURING, REPRODUCTION, USE AND SALES RIGHTS THERE TO, AND TO ANY ARTICLE DISCLOSED THEREIN EXCEPT TO THE EXTENT RIGHTS ARE EXPRESSLY GRANTED TO OTHERS. THE FOREGOING DOES NOT APPLY TO VENDOR PROPRIETARY PARTS.

REVISIONS				
ZONE	LTR	DESCRIPTION	DATE	APPROVED
	NC	PRODUCTION RELEASE	2-23-93	T. CSIK

NOTES: UNLESS OTHERWISE SPECIFIED.

1. REMOVE ALL BURRS AND BREAK SHARP EDGES.
 2. MAT'L: HANDLE-ALUM. ALLOY, ALL OTHER COMP'S-300 SERIES CRES.
 3. FINISH: HANDLE-CLEAR ANODIZE, CRES COMP'S-PASSIVATE.
 4. DECORATIVE FINISH: SATIN BUFF.
5. FOR -1, -3, -7 BOLT IS SPRING LOADED AND ALWAYS FREE TO LATCH.
6. FOR -5 BOLT IS DETENTED IN EXTENDED AND RETRACTED POSITIONS.
7. KEYING: FOUR DISC TUMBLER, KEYED ALIKE. KEYED DIFFERENT OR SPECIAL KEYING AVAILABLE ON SPECIAL ORDER. KEY IS REMOVABLE IN LOCKED AND UNLOCKED POSITIONS.
8. STATIC LOAD: 600 LBS.
9. STATIC LOAD: DETERMINED BY INSTALLATION.

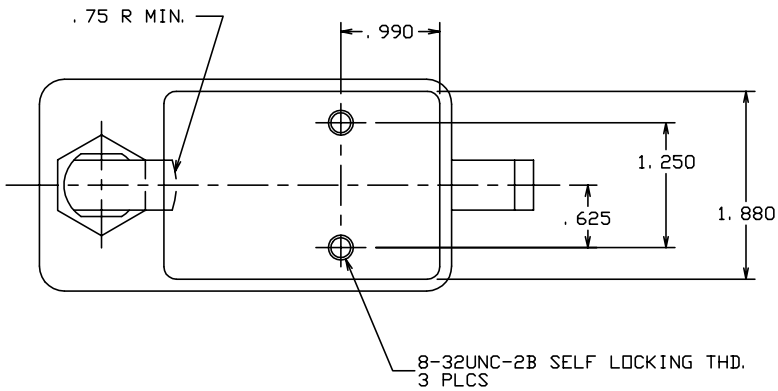
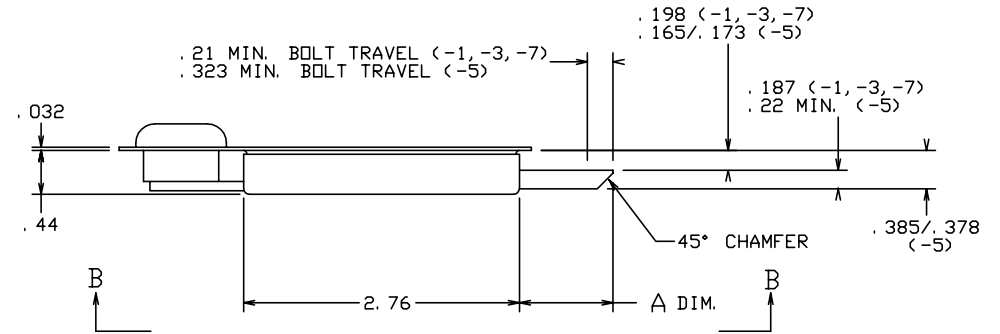
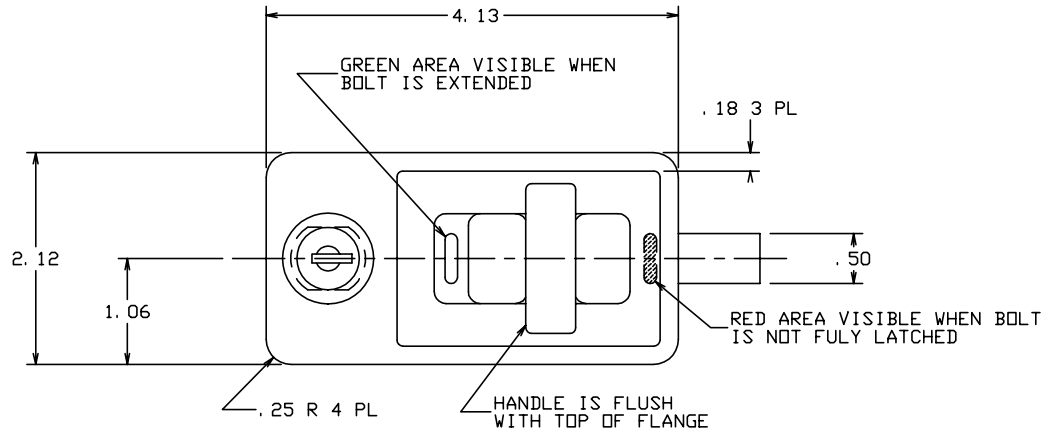

VIEW B-B

1.000	-7	LATCH ASSY	(SLAM)	6 8		
1.287	-5	LATCH ASSY	(DEADBOLT)	7 9		
1.22	-3	LATCH ASSY	(SLAM)	6 8		
.97	-1	LATCH ASSY	(SLAM)	6 8		
A DIM.	PART NO.	DESCRIPTION	MATERIAL	SIZE	SPECIFICATION	ITEM NO.

PARTS LIST					
UNLESS OTHERWISE SPECIFIED	DRAWN BY T. CSIK 2-23-93				
DIMENSIONS ARE IN INCHES	CHECKED				
TOLERANCES ON	ENGINEER				
DECIMALS ANGLES DRILLED HOLES	PROJECT				
.X ± .1 ± 0° 30' AND 10387	APPROVAL T. CSIK 2-23-93				
.XX ± .03					
.XXX ± .010					
DO NOT SCALE THIS DRAWING	APPROVAL				
MATERIAL - FINISH	USED ON	SIZE C	CODE IDENT. NO. 51941	DRAWING NO. 20818	REV. NC
NEXT ASSY		SCALE 1:1	VT.	SHEET 1 OF 1	
FINAL ASSY					

SKYLOCK INDUSTRIES INCORPORATED
MONROVIA CALIFORNIA U. S. A.

LATCH ASSY-LOCKING