

THE INFORMATION AND DESIGN HEREIN WAS ORIGINATED BY AND IS THE PROPERTY OF SKYLOCK INDUSTRIES INCORPORATED. SKYLOCK INDUSTRIES INCORPORATED RESERVES ALL PATENT, PROPRIETARY, DESIGN MANUFACTURING, REPRODUCTION, USE AND SALES RIGHTS THERE TO, AND TO ANY ARTICLE DISCLOSED THEREIN EXCEPT TO THE EXTENT RIGHTS ARE EXPRESSLY GRANTED TO OTHERS. THE FOREGOING DOES NOT APPLY TO VENDOR PROPRIETARY PARTS.

REVISIONS				
ZONE	LTR	DESCRIPTION	DATE	APPROVED
	NC	PRODUCTION RELEASE	8-25-93	T. CSIK
	A	REVISED PAWL TO AGREE WITH CUST. DWG.	10-11-93	T. CSIK
	B	DIMENSIONALLY REVISED TO AGREE WITH CUST. DWG.	12-15-93	T. CSIK

- NOTES: UNLESS OTHERWISE SPECIFIED.
- REMOVE ALL BURRS AND BREAK SHARP EDGES.
 - MAT'L: KNOB; ALUM. ALLOY, ALL OTHER PARTS; CRES.
 - FINISH: ALUM.; ANODIZE, CRES PARTS; PASSIVATE.
 - DECORATIVE FINISH: KNOB; BRIGHT BUFF AND CANDY APPLE RED ANODIZE.
 - STATIC LOAD: 1200 LBS. MAX.

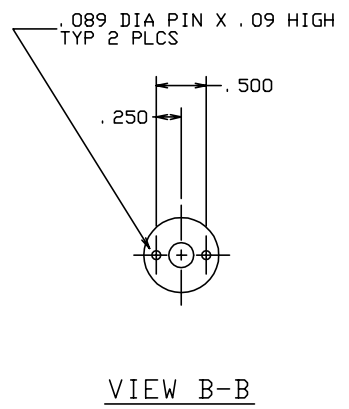
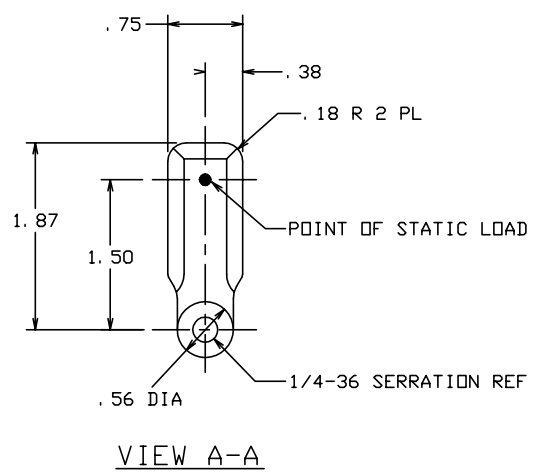
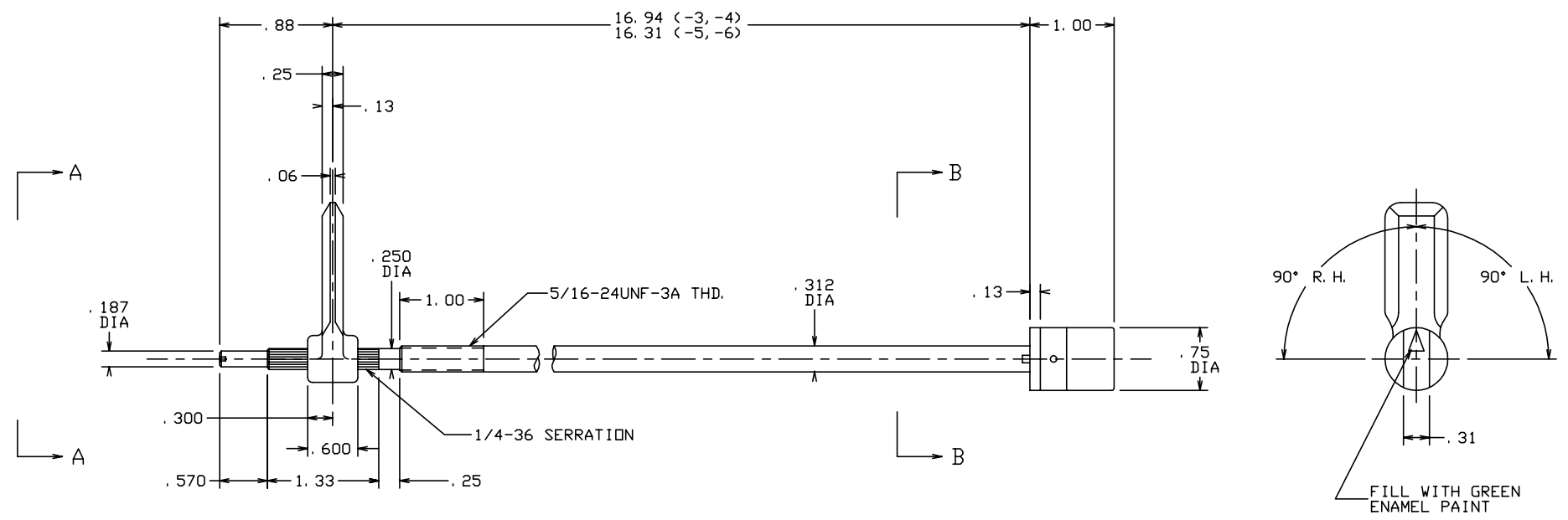

	-6	RETAINER ASSY	<90° RIGHT HAND, DETENTED AT EACH POSITION>		
	-5	RETAINER ASSY	<90° LEFT HAND, DETENTED AT EACH POSITION>		
	-4	RETAINER ASSY	<90° RIGHT HAND, DETENTED AT EACH POSITION>		
	-3	RETAINER ASSY	<90° LEFT HAND, DETENTED AT EACH POSITION>		
PART NO.	DESCRIPTION	MATERIAL	SIZE	SPECIFICATION	ITEM NO.

PARTS LIST					
UNLESS OTHERWISE SPECIFIED		DRAWN BY T. CSIK		8-25-93	
DIMENSIONS ARE IN INCHES		CHECKED			
TOLERANCES ON		ENGINEER			
DECIMALS ANGLES DRILLED HOLES		PROJECT			
.X ± .1 ± 0° 30' AND 10387		APPROVAL T. CSIK		8-25-93	
.XXX ± .010		APPROVAL			
DO NOT SCALE THIS DRAWING					
MATERIAL - FINISH		USED ON		SIZE	CODE IDENT. NO.
NEXT ASSY				C	51941
FINAL ASSY				DRAWING NO.	20853
				REV.	B
				SCALE	2:1
				WT.	
				SHEET	1 OF 1

SKYLOCK INDUSTRIES INCORPORATED
MONROVIA CALIFORNIA U. S. A.

REMOTE RETAINER ASSY