

THE INFORMATION AND DESIGN HEREIN WAS DEVELOPED BY AND IS THE PROPERTY OF SOLVEX INDUSTRIES INCORPORATED. SOLVEX INDUSTRIES INCORPORATED RESERVES ALL PATENT, PROPRIETARY, DESIGN MANUFACTURING INFORMATION, USE AND SALES RIGHTS HEREIN, AND TO ANY ARTICLES DEVELOPED THEREIN EXCEPT TO THE EXTENT RIGHTS ARE EXPRESSLY GRANTED TO OTHERS. THE FOREGOING DOES NOT APPLY TO NON-PATENTABLE PARTS.

- NOTES: UNLESS OTHERWISE SPECIFIED.
1. REMOVE ALL BURRS AND BREAK SHARP EDGES.
 2. MAT'L: *D* HANDLE AND TEE BAR; 6061-T6 ALUM. ALLOY, ALL OTHER PARTS; 300 SERIES CRES.
 3. FINISH: ALUM.; CLEAR ANODIZE PER MIL-A-8625E. ST. STL.; CLEAN AND PASSIVATE.
 4. DECORATIVE FINISH: HANDLE AND CUP ARE SATIN BRUSHED ON TOP SURFACES.
 5. BOLTS ARE SPRING LOADED TO THE ENGAGED POSITION.
 6. *D* HANDLE TO BE SPRING LOADED DOWN.
 7. USE WITH 20177-3 BACKPLATE, ORDERED SEPARATELY.

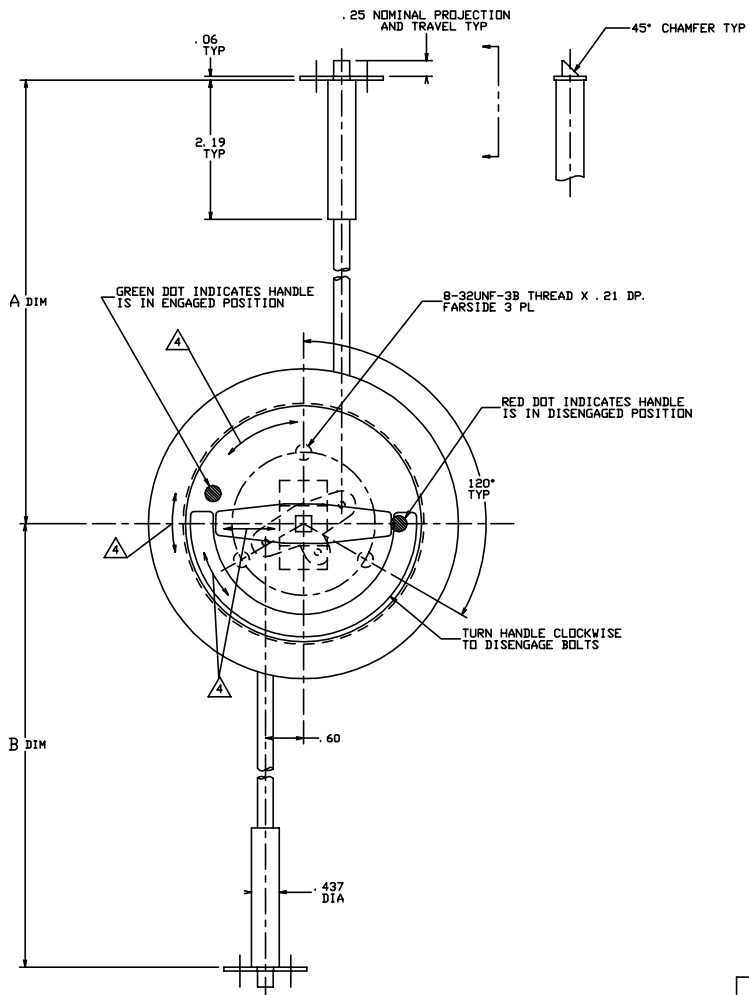

REVISIONS				
ZONE	LTR	DESCRIPTION	DATE	APPROVED
NC		PRODUCTION RELEASE	10-20-93	T. C.

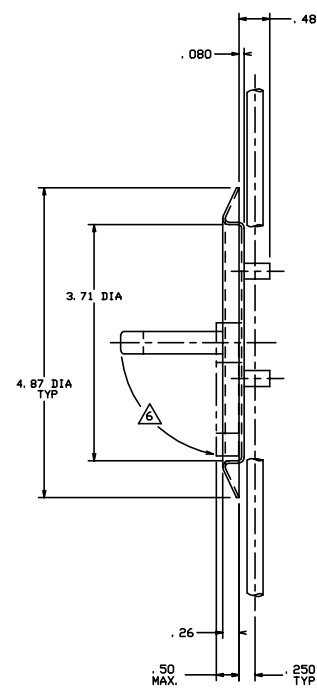

EXAMPLE:

20868-401-100-100

	A DIM. @ 10.0 INCHES	B DIM. @ 10.0 INCHES
-402	FIRST TWO DIGITS (INCHES) THIRD DIGIT (TENTH IN.) A DIM.	FIRST TWO DIGITS (INCHES) THIRD DIGIT (TENTH IN.) B DIM.
-401	FIRST TWO DIGITS (INCHES) THIRD DIGIT (TENTH IN.) A DIM.	FIRST TWO DIGITS (INCHES) THIRD DIGIT (TENTH IN.) B DIM.
FIRST DASH NO.	SECOND DASH NO.	THIRD DASH NO.
TABULATION BLOCK		

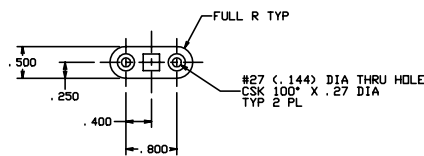

SEE TABULATION BLOCK FOR ORDERING INFORMATION

	-402	BOLTING SYSTEM	(DPP. -401)	
	-401	BOLTING SYSTEM	(SHOWN)	
QTY REQD	PART NO.	DESCRIPTION	MATERIAL	SIZE SPECIFICATION
PARTS LIST				
UNLESS OTHERWISE SPECIFIED		DRAWN BY	T. CSIK	10-20-93
DIMENSIONS ARE IN INCHES		CHECKED		
TOLERANCES ON DECIMALS		ENGINEER		
ANGLES		PROJECT		
DRILL HOLES		APPROVAL	T. CSIK	10-20-93
DO NOT SCALE THIS DRAWING		APPROVAL		
MATERIAL - FINISH		USED ON		
NEXT ASBY		SIZE	D	CODE IDENT. NO.
FINAL ASBY		SCALE	1:1	DRIVING NO.
		VT.		REV.
				NC
				SHEET 1 OF 1



DOOR BOLTING SYSTEM
2 POINT - SLAM