

THE INFORMATION AND DESIGN HEREIN WAS DEVELOPED BY AND IS THE PROPERTY OF SLYDOK INDUSTRIES INCORPORATED. SLYDOK INDUSTRIES INCORPORATED RESERVES ALL PATENT, PROPRIETARY, DESIGN MANUFACTURING INFORMATION, USE AND SALES RIGHTS HEREIN, AND TO ANY ARTICLES DEVELOPED THEREIN EXCEPT TO THE EXTENT RIGHTS ARE EXPRESSLY GRANTED TO OTHERS. THE FOREGOING DOES NOT APPLY TO NON-PATENTABLE MATTER.

NOTES: UNLESS OTHERWISE SPECIFIED.

1. MAT'L: CASE AND HANDLE - ALUM. ALLOY; BUSHING - BRONZE; ALL OTHER COMPONENTS - CRES.
2. FINISH: ALUM. PARTS - ANODIZE; CRES PARTS - PASSIVATE.
3. ULTIMATE TORQUE ON HANDLE MECHANISM IS 300 IN/LBS.
4. HANDLE IS SPRING LOADED TO THE FLUSH CONDITION.
5. LETTERING IS ENGRAVED .25" HIGH AND FILLED WITH BLACK ENAMEL PAINT.
6. DECORATIVE FINISH: HANDLE - SATIN BUFF AND CLEAR BAKED ENAMEL.

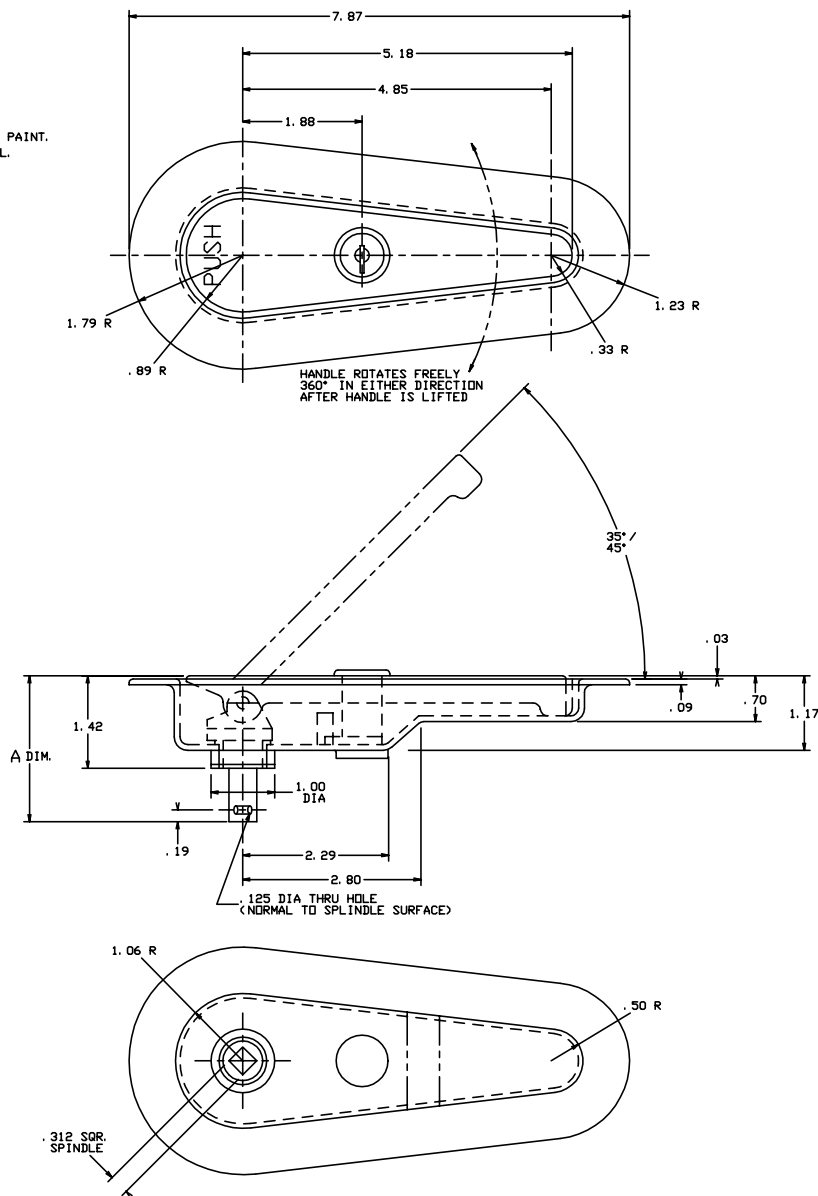

REVISIONS				
ZONE	LTR	DESCRIPTION	DATE	APPROVED
	NC	PRODUCTION RELEASE	11-8-93	T. CSIK
	A	REVISED 'A' DIM. IS 2.250, WAS 2.375	11-17-93	T. CSIK
	B	DIM. 2.29 - WAS 2.58, DIM. 2.80 - WAS 3.09 REVISED PER CUSTOMER REQUEST	12-3-93	T. CSIK

2.250	-401	HANDLE ASSY		
A DIM.	PART NO.	DESCRIPTION	MATERIAL	SIZE SPECIFICATION
PARTS LIST				
UNLESS OTHERWISE SPECIFIED		DRAWN BY T. CSIK	10-01-93	 SLYDOK INDUSTRIES INCORPORATED REDWOODIA CALIFORNIA
DIMENSIONS ARE IN INCHES		CHECKED		
TOLERANCES ON		DESIGNED		HANDLE ASSY
DECIMALS ANGLES DRILLED HOLES		PROJECT		
.001" .010" .015" .030" .050"		APPROVAL T. CSIK	10-08-93	
DO NOT SCALE THIS DRAWING		APPROVAL		
MATERIAL - FINISH	USED ON	SIZE	CODE IDENT. NO.	DRAWING NO.
		D	51941	20869
NEXT ASSY		SCALE	1:1	REV. B
FINAL ASSY		VT.		SHEET 1 OF 1