

THE INFORMATION AND DESIGN HEREIN WAS ORIGINATED BY AND IS THE PROPERTY OF SKYLOCK INDUSTRIES INCORPORATED. SKYLOCK INDUSTRIES INCORPORATED RESERVES ALL PATENT, PROPRIETARY, DESIGN MANUFACTURING, REPRODUCTION, USE AND SALES RIGHTS THERE TO, AND TO ANY ARTICLE DISCLOSED THEREIN EXCEPT TO THE EXTENT RIGHTS ARE EXPRESSLY GRANTED TO OTHERS. THE FOREGOING DOES NOT APPLY TO VENDOR PROPRIETARY PARTS.

REVISIONS				
ZONE	LTR	DESCRIPTION	DATE	APPROVED
	NC	PRODUCTION RELEASE	10-29-93	T. CSIK
	A	REVISED PER CUSTOMER FAX DATED 10-29-93	11-8-93	T. CSIK

- NOTES: UNLESS OTHERWISE SPECIFIED.
1. REMOVE ALL BURRS AND BREAK SHARP EDGES.
  2. MAT'L: LATCH HOUSING AND HANDLE - ALUM. ALLOY, HOOK AND BALL DETENT - ST. STL., BUSHINGS - PHOS. BRONZE, STRIKER - ST. STL.
  3. DECORATIVE FINISH: SATIN BUFF.
  4. PROTECTIVE FINISH: ALUM. ALLOY - CLEAR ANODIZE, ST. STL. - PASSIVATE.
  5. LATCH HOOK IS DETENTED IN THE LOCKED AND UNLOCKED POSITIONS.
  6. STATIC LOAD: 1200 LBS. MAX.

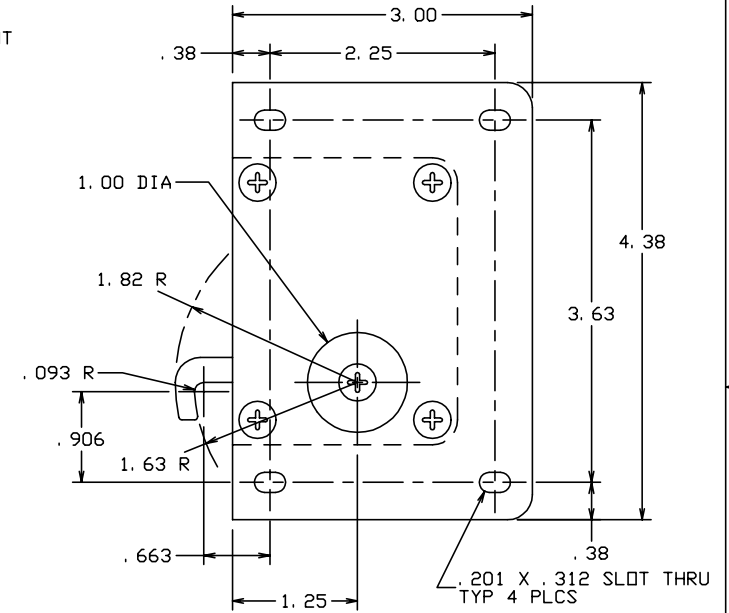
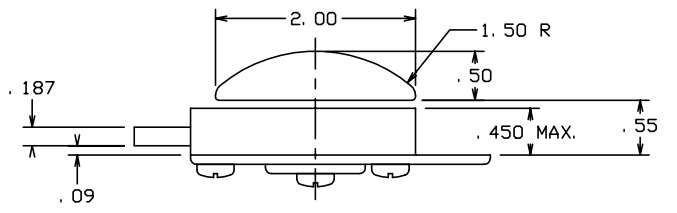
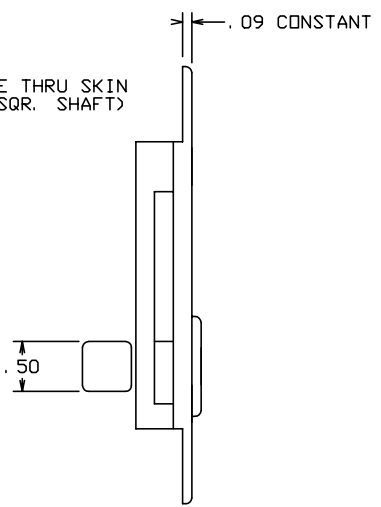
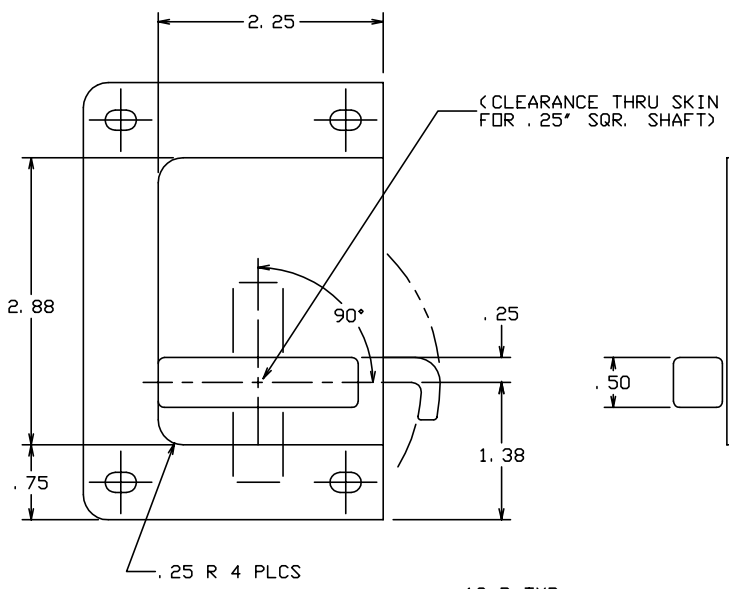

-401 LATCH ASSY (SHOWN)  
 -402 LATCH ASSY (OPP.)

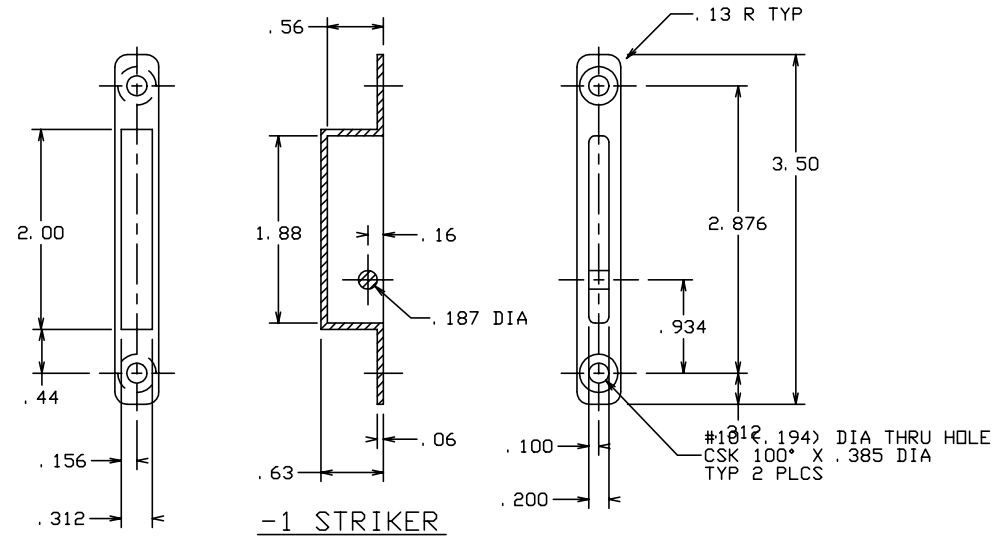

QTY REQD	PART NO.	DESCRIPTION	MATERIAL	SIZE	SPECIFICATION	ITEM NO.
	-1	STRIKER				
	-402	LATCH ASSY				
	-401	LATCH ASSY				

PARTS LIST		DRAWN BY T. CSIK 10-29-93		SKYLOCK INDUSTRIES INCORPORATED MONROVIA CALIFORNIA U. S. A.	
UNLESS OTHERWISE SPECIFIED		CHECKED		<div style="text-align: center;"> <h3>LATCH ASSY - ROTARY HOOK</h3> </div>	
DIMENSIONS ARE IN INCHES		ENGINEER			
TOLERANCES ON		PROJECT			
DECIMALS ANGLES DRILLED HOLES		APPROVAL T. CSIK 10-29-93			
.X ± .1 ± 0° 30' AND 10387		APPROVAL		SIZE CODE IDENT. NO. DRAWING NO. REV.	
.XX ± .03				C 51941 20873 A	
.XXX ± .010				SCALE 1:2 WT. SHEET 1 OF 1	
DO NOT SCALE THIS DRAWING					
MATERIAL - FINISH		USED ON			
NEXT ASSY					
FINAL ASSY					