

THE INFORMATION AND DESIGN HEREIN WAS ORIGINATED BY AND IS THE PROPERTY OF SKYLOCK INDUSTRIES INCORPORATED. SKYLOCK INDUSTRIES INCORPORATED RESERVES ALL PATENT, PROPRIETARY, DESIGN MANUFACTURING, REPRODUCTION, USE AND SALES RIGHTS THERE TO, AND TO ANY ARTICLE DISCLOSED THEREIN EXCEPT TO THE EXTENT RIGHTS ARE EXPRESSLY GRANTED TO OTHERS. THE FOREGOING DOES NOT APPLY TO VENDOR PROPRIETARY PARTS.

REVISIONS				
ZONE	LTR	DESCRIPTION	DATE	APPROVED
	NC	PRODUCTION RELEASE	1-21-94	T. C.
	A	ADDED -7	2-21-95	T. C.

- NOTES: UNLESS OTHERWISE SPECIFIED.
- MAT'L: HANDLE; 6061-T6 ALUM. ALLOY, ALL OTHER COMPS; CRES.
  - FINISH: SATIN BUFF HANDLE AND CASE FLANGE.
  - STATIC LOAD 600 LBS.
  - BOLT IS DETENTED AT THE EXTENDED AND RETRACTED POSITIONS.

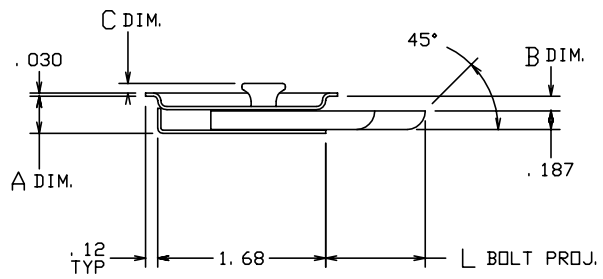
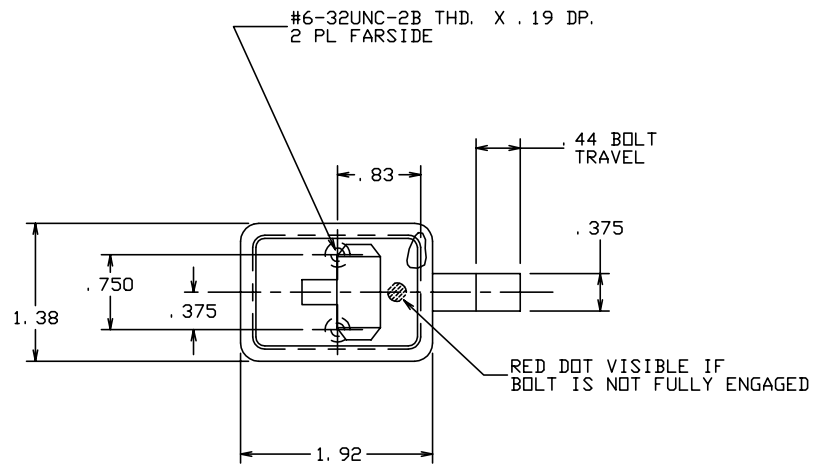

-1, -3, -5 SHOWN

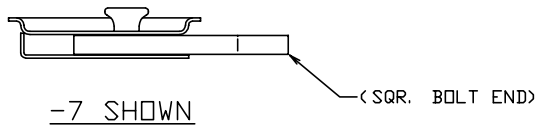

20881-1-2

BASIC P/N

SECONDARY DASH NO.

PRIMARY DASH NO.

EXAMPLE P/N

1.00	-12
.91	-10
.81	-8
.75	-6
.62	-4
.50	-2
L BOLT PROJ.	SECONDARY DASH NO.

.12	.19	.42	-7
.00	.31	.54	-5
.12	.19	.42	-3
.19	.12	.35	-1
C DIM	B DIM	A DIM	PRIMARY DASH NO.

UNLESS OTHERWISE SPECIFIED	DRAWN BY T. CSIK	11-29-93	SKYLOCK INDUSTRIES INCORPORATED MONROVIA CALIFORNIA U. S. A.		
DIMENSIONS ARE IN INCHES	CHECKED				
TOLERANCES ON	ENGINEER		LATCH ASSY - DEADBOLT		
DECIMALS ANGLES DRILLED HOLES	PROJECT				
.X ± .1 ± 0° 30' AND 10387 .XX ± .03 .XXX ± .010	APPROVAL T. CSIK	11-29-93			
DO NOT SCALE THIS DRAWING	APPROVAL				
MATERIAL - FINISH	USED ON	SIZE C	CODE IDENT. NO. 51941	DRAWING NO. 20881	REV. A
NEXT ASSY		SCALE 1:1	VT.	SHEET 1	OF 1
FINAL ASSY					