

THE INFORMATION AND DESIGN HEREIN WAS ORIGINATED BY AND IS THE PROPERTY OF SOLIDEX INDUSTRIES INCORPORATED. SOLIDEX INDUSTRIES INCORPORATED RESERVES ALL PATENT, PROPRIETARY, DESIGN MANUFACTURING INFORMATION, USE AND SALES RIGHTS HEREIN, AND TO ANY ARTICLES DEVELOPED THEREIN EXCEPT TO THE EXTENT RIGHTS ARE EXPRESSLY GRANTED TO OTHERS. THE FOREGOING DOES NOT APPLY TO NON-PATENTABLE IDEAS.

NOTES: UNLESS OTHERWISE SPECIFIED.

1. REMOVE ALL BURRS AND BREAK SHARP EDGES.
2. MAT'L: TRACK; ALUM ALLOY, HANDLE, PLUG, BRACKET RETAINERS; PLASTIC, CABLE; ST. STL. CABLE W/ NYLON JACKET.
3. FINISH: ALUM.; CLEAR ANODIZE PER MIL-A-8625, TYPE II, CLASS I. ST. STL.) PASSIVATE PER QQ-P-35.
4. HANDLE AND BRACKET ARE SPRING LOADED TO THE RETRACTED POSITION.

REVISIONS				
ZONE	LTR	DESCRIPTION	DATE	APPROVED
	NC	PRODUCTION RELEASE	3-2-94	T. C.
	A	ADDED -421	3-9-94	T. C.
	B	ADDED -423	7-15-94	T. C.
	C	ADDED -425	11-11-94	T. C.
	D	ADDED -427, -429, -431	4-4-95	T. C.
	E	ADDED -433	6-14-95	T. C.
	F	ADDED -435	8-16-95	T. C.
	G	ADDED -437	2-6-97	T. C.
	H	G/N B ADDED "CABLE; ST. STL CABLE W/ NYLON JACKET". (PRODUCT IMPROVEMENT)	7-23-97	T. C.

-437	EXTRACTOR ASSY	(SEE SHT. 5)	31.45	16.55	3.00
-435	EXTRACTOR ASSY	(SEE SHT. 3)	35.94	18.50	3.00
-433	EXTRACTOR ASSY	(SEE SHT. 4)	33.00	14.75	3.00
-431	EXTRACTOR ASSY	(SEE SHT. 5)	31.18	17.75	1.62
-429	EXTRACTOR ASSY	(SEE SHT. 4)	34.18	14.75	3.00
-427	EXTRACTOR ASSY	(SEE SHT. 4)	33.50	14.75	3.00
-425	EXTRACTOR ASSY	(SEE SHT. 4)	34.00	19.00	3.00
-423	EXTRACTOR ASSY	(SEE SHT. 4)	32.00	17.75	1.62
-421	EXTRACTOR ASSY	(SEE SHT. 3)	31.50	18.40	1.62
-419	EXTRACTOR ASSY	(SEE SHT. 3)	30.00	14.75	3.00
-417	EXTRACTOR ASSY	(SEE SHT. 2)	30.00	14.75	4.50
-415	EXTRACTOR ASSY	(SEE SHT. 2)	16.50	7.75	3.75
-413	EXTRACTOR ASSY	(SEE SHT. 2)	21.25	12.50	1.62
-411	EXTRACTOR ASSY	(SEE SHT. 2)	28.50	11.00	3.00
-409	EXTRACTOR ASSY	(SEE SHT. 2)	24.80	9.00	3.00
-407	EXTRACTOR ASSY	(SEE SHT. 2)	30.50	14.75	1.62
-405	EXTRACTOR ASSY	(SEE SHT. 2)	30.00	14.75	3.00
-403	EXTRACTOR ASSY	(SEE SHT. 2)	30.50	14.75	1.25
-401	EXTRACTOR ASSY	(SEE SHT. 2)	33.50	14.75	3.75
PART NO.	DESCRIPTION		A DIM.	B DIM.	C DIM.

PARTS LIST		DRAWN BY		DATE	
		T. CSIK		2-28-94	
		S. CSIK		3-8-94	
		T. CSIK		3-8-94	
		PROJECT			
		APPROVAL			
		D. SHORT		3-8-94	
		USED ON			
		SIZE		CODE IDENT. NO.	
		D		51941	
		DRAWING NO.		20884	
		REV.		H	
		SCALE		NONE	
		SHEET		1 OF 5	

SOLIDEX INDUSTRIES INCORPORATED
MORNOVA CALIFORNIA

EXTRACTOR ASSY

REVISIONS				
ZONE	LTR	DESCRIPTION	DATE	APPROVED
		SEE SHT. 1 FOR NOTES		

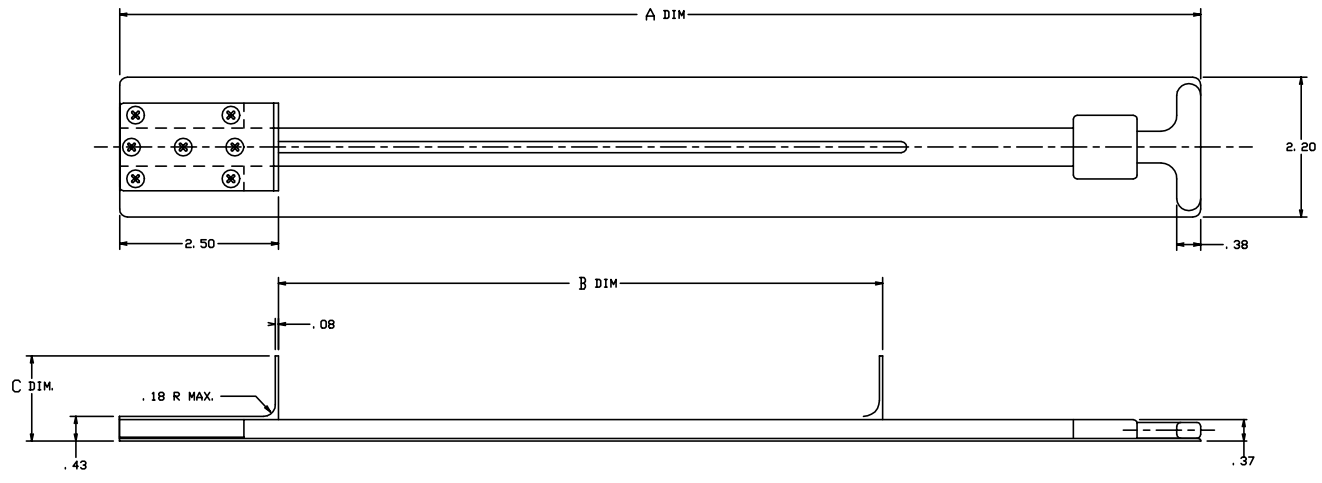

-401, -403, -415, -417

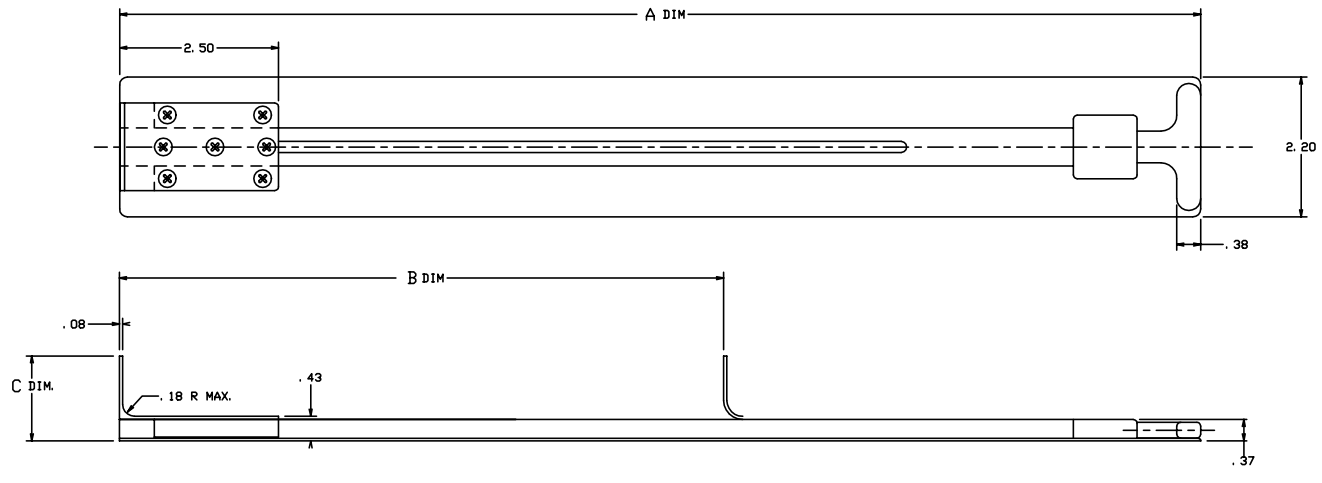
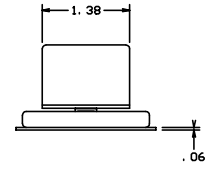

-405 THRU -413

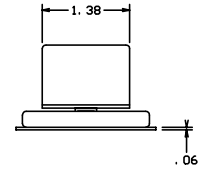

 SOLDEX INDUSTRIES INCORPORATED REDWOOD CITY, CALIFORNIA			
EXTRACTOR ASSY			
SIZE D	CODE IDENT. NO. 51941	DRAWING NO. 20884	REV. H
SCALE NONE	VT.	SHEET 2 OF	

REVISIONS				
ZONE	LTR	DESCRIPTION	DATE	APPROVED
		SEE SHT. 1 FOR NOTES		

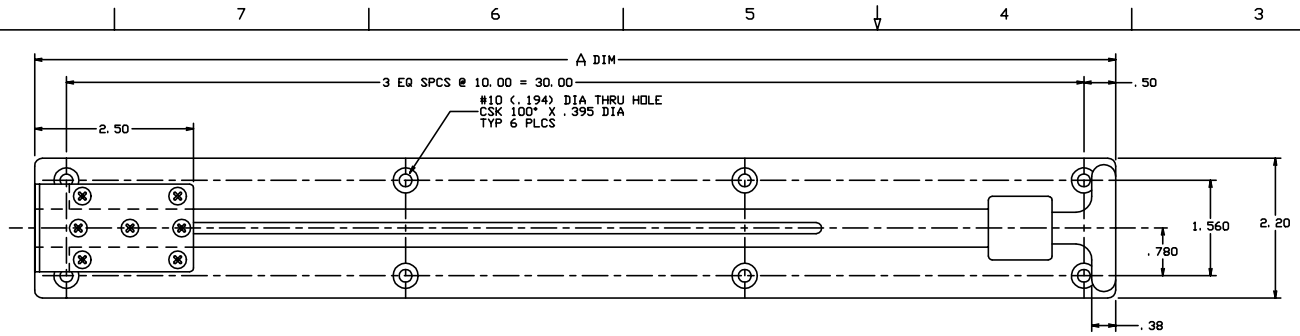

-421

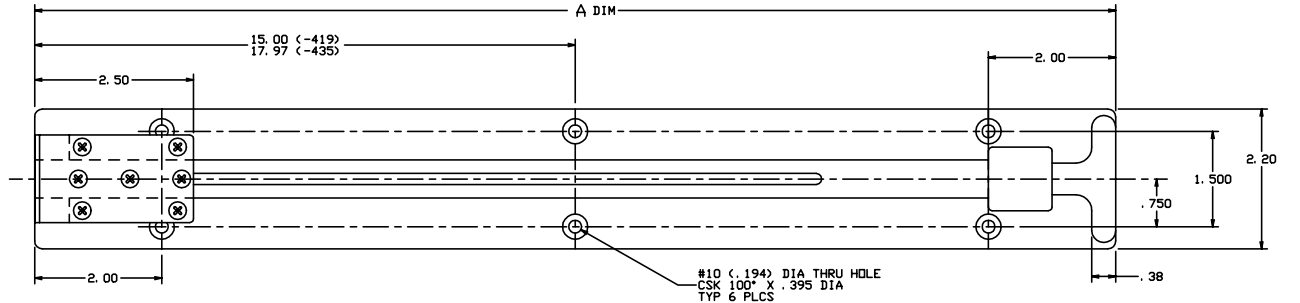

-419
-435

SOLDEX INDUSTRIES, INCORPORATED
 REDWOOD CITY, CALIFORNIA

EXTRACTOR ASSY

SIZE D	CODE IDENT. NO. 51941	DRAWING NO. 20884	REV. H
SCALE NONE	VT.	SHEET 3 OF	

REVISIONS				
ZONE	LTR	DESCRIPTION	DATE	APPROVED
		SEE SHT. 1 FOR NOTES		

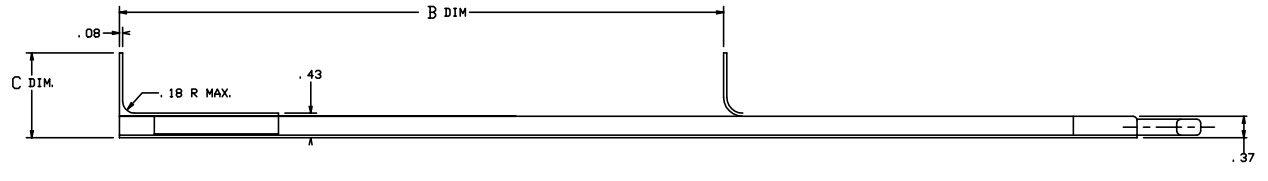
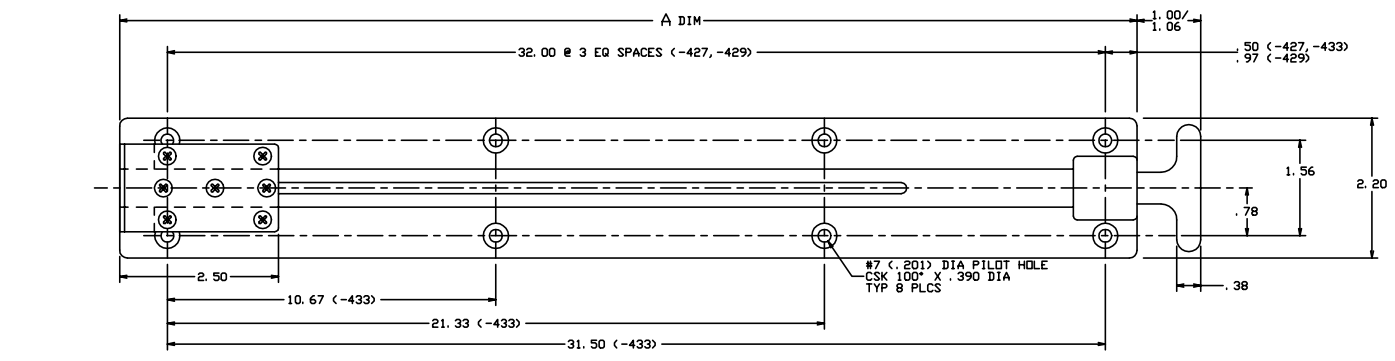

-427
-429
-433

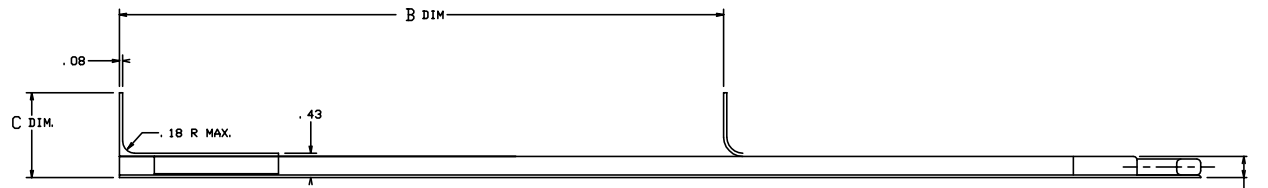
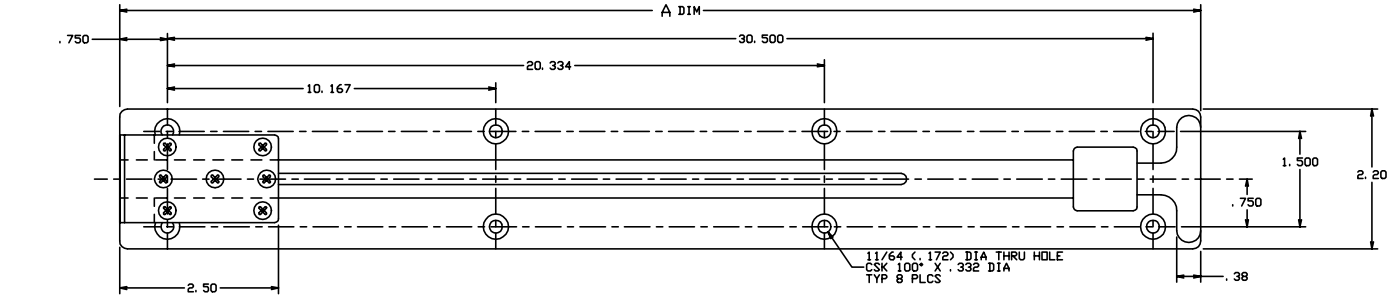
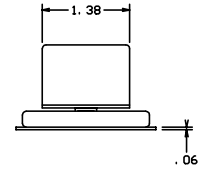

-423
-425

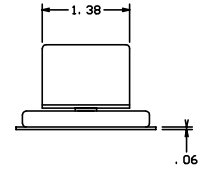

SOLDEX INDUSTRIES, INCORPORATED
 REDWOOD CITY, CALIFORNIA

EXTRACTOR ASSY

SIZE D	CODE IDENT. NO. 51941	DRAWING NO. 20884	REV. H
SCALE NONE	VT.	SHEET 4 OF	

REVISIONS				
ZONE	LTR	DESCRIPTION	DATE	APPROVED
		SEE SHT. 1 FOR NOTES		

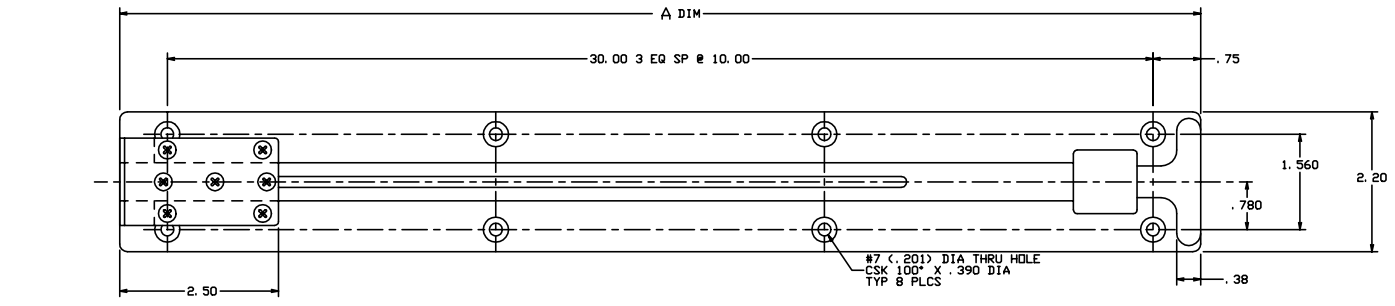

-437

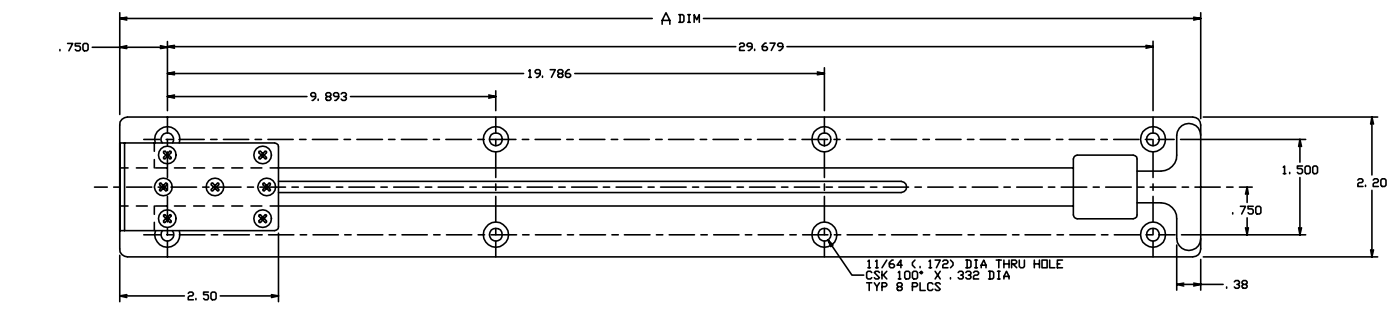

-431

 SOLDEX INDUSTRIES, INCORPORATED REDWOOD CITY, CALIFORNIA			
EXTRACTOR ASSY			
SIZE D	CODE IDENT. NO. 51941	DRAWING NO. 20884	REV. H
SCALE NONE	VT.	SHEET 5 OF	