

THE INFORMATION AND DESIGN HEREIN WAS ORIGINATED BY AND IS THE PROPERTY OF SKYLOCK INDUSTRIES INCORPORATED. SKYLOCK INDUSTRIES INCORPORATED RESERVES ALL PATENT, PROPRIETARY, DESIGN MANUFACTURING, REPRODUCTION, USE AND SALES RIGHTS THERE TO, AND TO ANY ARTICLE DISCLOSED THEREIN EXCEPT TO THE EXTENT RIGHTS ARE EXPRESSLY GRANTED TO OTHERS. THE FOREGOING DOES NOT APPLY TO VENDOR PROPRIETARY PARTS.

REVISIONS				
ZONE	LTR	DESCRIPTION	DATE	APPROVED
	NC	PRODUCTION RELEASE	9-2-97	T. CSIK

- NOTES: UNLESS OTHERWISE SPECIFIED.
1. REMOVE ALL BURRS AND BREAK SHARP EDGES.
 2. MAT'L: RETAINER; ALUM. ALLOY, ALL OTHER PARTS; 300 SERIES CRES.
 3. FINISH: ALUM.; ANODIZE, CRES PARTS; PASSIVATE.
 4. DECORATIVE FINISH: RETAINER; BRIGHT BUFF AND CANDY APPLE RED ANODIZE.

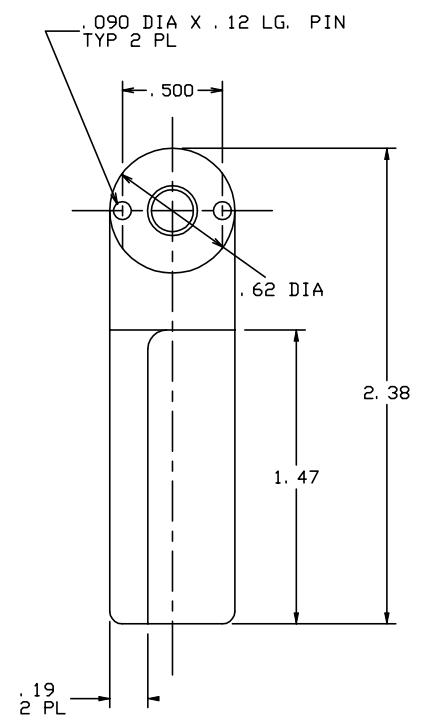
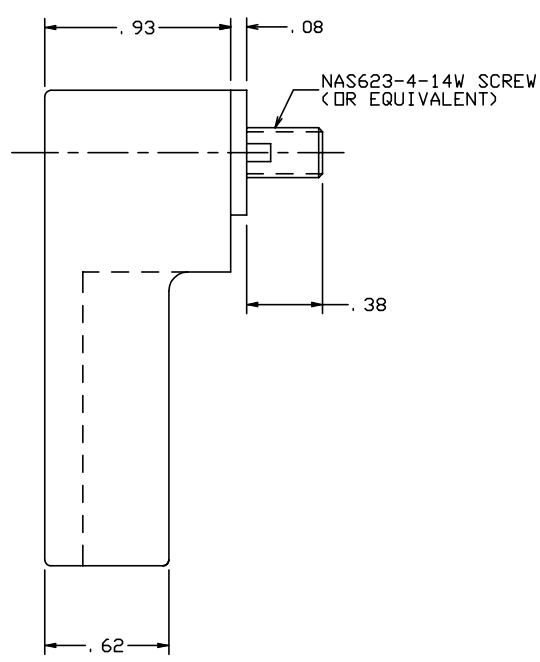
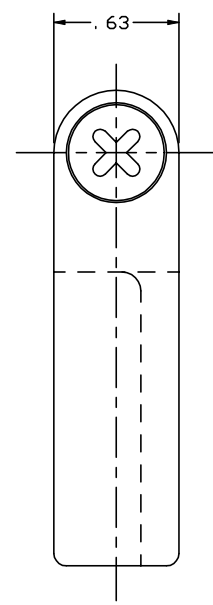

-1		1/4 TURN RETAINER (90° RIGHT HAND)		
PART NO.	DESCRIPTION	MATERIAL	SIZE	SPECIFICATION
PARTS LIST				
UNLESS OTHERWISE SPECIFIED		DRAWN BY	T. CSIK	8-29-97
DIMENSIONS ARE IN INCHES		CHECKED		
TOLERANCES ON		ENGINEER		
DECIMALS	ANGLES	DRILLED HOLES	PROJECT	
.X ± .1	± 0° 30'	AND 10387	APPROVAL	
.XX ± .03			APPROVAL	
.XXX ± .010			APPROVAL	
DO NOT SCALE THIS DRAWING		APPROVAL		
MATERIAL - FINISH	USED ON	SIZE	CODE IDENT. NO.	DRAWING NO.
NEXT ASSY		C	51941	20948
FINAL ASSY		SCALE	2: 1	VT.
			SHEET	1 OF 1

SKYLOCK INDUSTRIES INCORPORATED
MONROVIA CALIFORNIA U. S. A.

1/4 TURN RETAINER

REV. NC