

THE INFORMATION AND DESIGN HEREIN WAS ORIGINATED BY AND IS THE PROPERTY OF SKYLOCK INDUSTRIES INCORPORATED. SKYLOCK INDUSTRIES INCORPORATED RESERVES ALL PATENT, PROPRIETARY, DESIGN MANUFACTURING, REPRODUCTION, USE AND SALES RIGHTS THERE TO, AND TO ANY ARTICLE DISCLOSED THEREIN EXCEPT TO THE EXTENT RIGHTS ARE EXPRESSLY GRANTED TO OTHERS. THE FOREGOING DOES NOT APPLY TO VENDOR PROPRIETARY PARTS.

REVISIONS				
ZONE	LTR	DESCRIPTION	DATE	APPROVED
	NC	PRODUCTION RELEASE	9-29-98	T. C.
	A	SEE ECN A	12-3-98	T. C.

NOTES: UNLESS OTHERWISE SPECIFIED.

- MAT'L: HANDLE; 6061-T6/T651 PER ASTM B-221, OR EQUIV. ALL OTHER COMPS; 302-304 CRES, COND. A, PER ASTM-A-240 OR EQUIV.
- FINISH: HANDLE; CLEAR ANODIZE, PER MIL-A-8625, TYPE II, CLASS I. CRES.; CLEAN AND PASSIVATE PER AMS-QQ-P-35, TYPE VI OR VII.
- DECORATIVE FINISH: SATIN BUFF.
- BOLT IS DETENTED IN EXTENDED AND RETRACTED POSITIONS.
- PER FAR 45.15. PARTS WILL IDENTIFIED WITH:
 - FAA-PMA.
 - SKYLOCK IND. INC.
 - PART NO.
 - AIRCRAFT ELIGIBILITY.

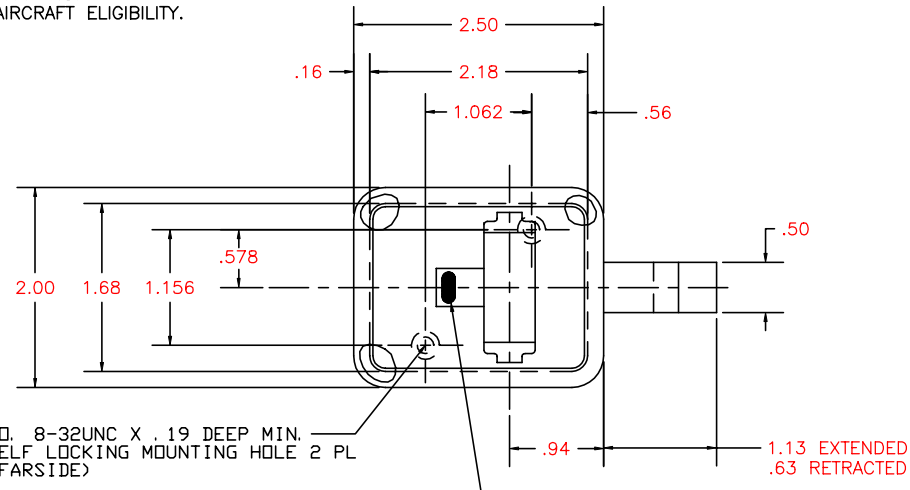

GREEN DOT IS SHOWN WHEN BOLT IS EXTENDED-RED DOT IS SHOWN WHEN BOLT IS NOT FULLY LATCHED

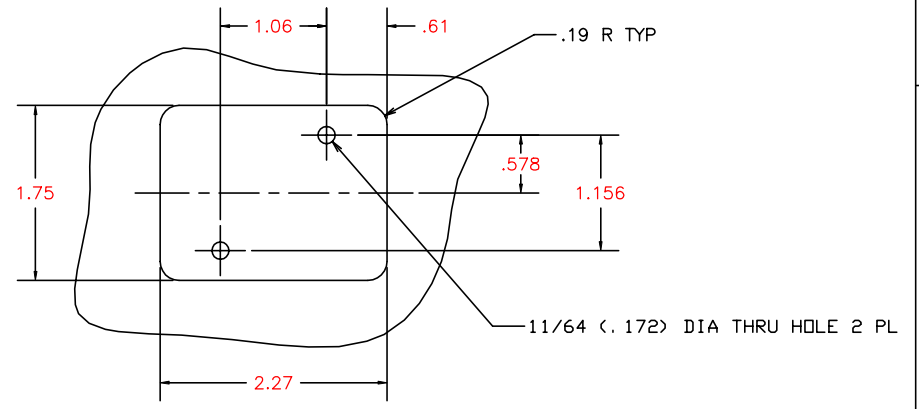

DOOR CUTOUT INFORMATION

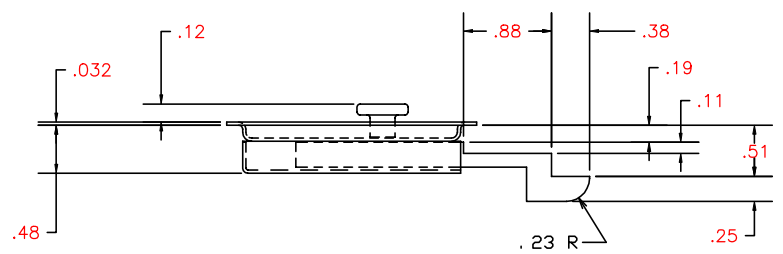

-1 LATCH						
ADIM	PART NO.	DESCRIPTION	MATERIAL	SIZE	APPLICATION	ITEM NO.
PARTS LIST						
UNLESS OTHERWISE SPECIFIED		DRAWN BY	T. CSIK	9-29-98	SKYLOCK INDUSTRIES INCORPORATED MONROVIA CALIFORNIA U. S. A.	
DIMENSIONS ARE IN INCHES		CHECKED	E. WELSH	12-2-98		
TOLERANCES ON		ENGINEER	T. CSIK	12-2-98		
DECIMALS ANGLES DRILLED HOLES		MFG	P. M.	12-15-98		
.X .1 0° 30' AND 10387		Q. C.	J. V.	12-28-98	LATCH	
.XX .03						
.XXX .010						
DO NOT SCALE THIS DRAWING						
MATERIAL - FINISH			SIZE	CODE IDENT. NO.	DRAWING NO.	REV.
MANUFACTURED IN ACCORDANCE WITH SKYLOCK IND. INC. QUALITY CONTROL MANUAL QC.001			C	51941	20962	A
SCALE 1: 1			VT.	SHEET 1 OF 1		