

THE INFORMATION AND DESIGN HEREIN WAS ORIGINATED BY AND IS THE PROPERTY OF SKYLOCK INDUSTRIES INCORPORATED. SKYLOCK INDUSTRIES INCORPORATED RESERVES ALL PATENT, PROPRIETARY, DESIGN MANUFACTURING, REPRODUCTION, USE AND SALES RIGHTS THERE TO, AND TO ANY ARTICLE DISCLOSED THEREIN EXCEPT TO THE EXTENT RIGHTS ARE EXPRESSLY GRANTED TO OTHERS. THE FOREGOING DOES NOT APPLY TO VENDOR PROPRIETARY PARTS.

REVISIONS				
ZONE	LTR	DESCRIPTION	DATE	APPROVED
	NC	PRODUCTION RELEASE	2/8/99	T. CSIK

NOTES: UNLESS OTHERWISE SPECIFIED.

- REMOVE ALL BURRS AND BREAK SHARP EDGES.
- MAT'L REF.: RETAINER; 6061-T6/T651 PER ASTM B-221 OR EQUIV.
ALL OTHER PARTS; 303 CRES, COND. A, PER AMS-5640N OR EQUIV.
- FINISH REF.: ALUM.; CLEAR ANODIZE PER MIL-A-8625, TYPE II, CLASS 1, OR EQUIV.
CRES PARTS; PASSIVATE PER AMS-QQ-P-35, TYPE II, OR EQUIV.
- DECORATIVE FINISH REF.: RETAINER; BRIGHT BUFF AND ANODIZE PER MIL-A-8625, TYPE II, CLASS 2 DYED CANDY APPLE RED, OR EQUIV.

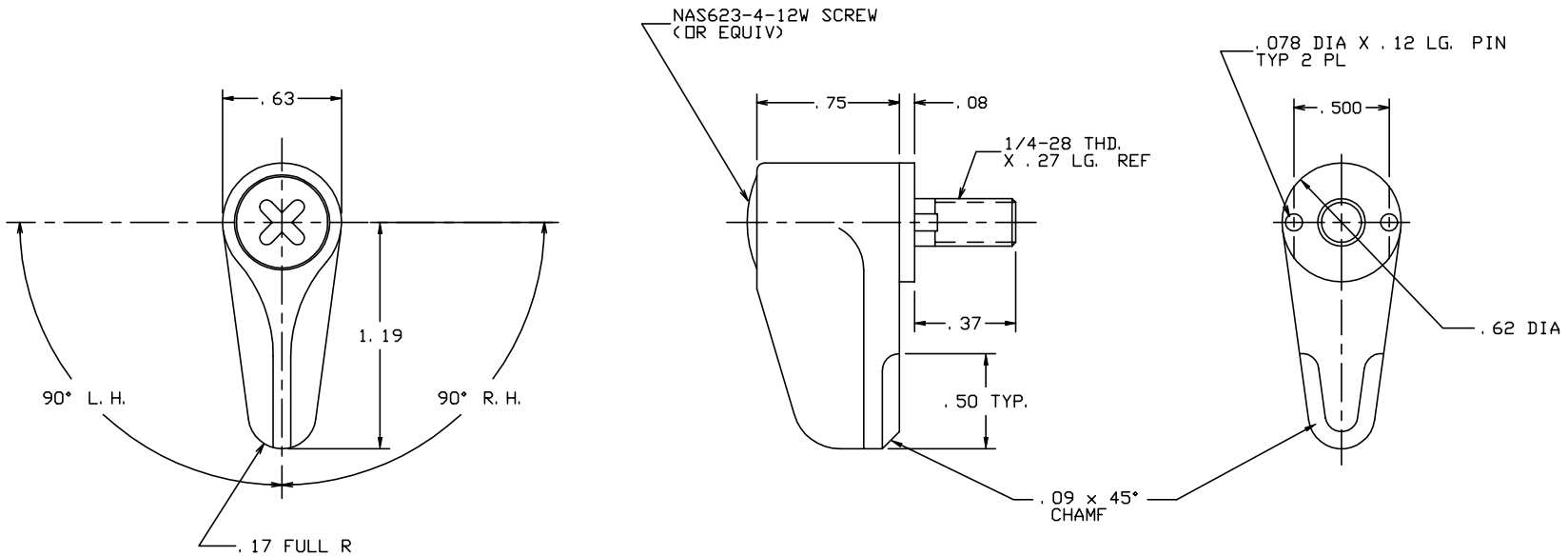

	-3	RETAINER	<180°	120965-3	
	-2	RETAINER	<90° RIGHT HAND	120965-2	
	-1	RETAINER	<90° LEFT HAND	120965-1	
PART NO.	DESCRIPTION	MATERIAL	SIZE	SPECIFICATION	MAKE FROM

PARTS LIST					
UNLESS OTHERWISE SPECIFIED	DRAWN BY	ED WELCH	2/8/99	 SKYLOCK INDUSTRIES INCORPORATED MONROVIA CALIFORNIA U. S. A.	20965 RETAINER
DIMENSIONS ARE IN INCHES	CHECKED	T. CSIK	2/8/99		
TOLERANCES ON	ENGINEER	T. CSIK	2/8/99		
DECIMALS ANGLES DRILLED HOLES	MFG	P. MATSUOKA	2/10/99		
.X ± .1 ± 0° 30' AND 10387	QC	J. VIVIRITO	2/25/99		
.XX ± .03					
.XXX ± .010					
DO NOT SCALE THIS DRAWING					
MATERIAL - FINISH	USED ON	SIZE	CODE IDENT. NO.	DRAWING NO.	REV.
NEXT ASSY		C	51941	20965	NC
MANUFACTURE IN ACCORDANCE WITH SKYLOCK IND. INC., QUALITY CONTROL MANUAL QC 001		SCALE	2:1	VT.	SHEET 1 OF 1