

4

3

2

1

THE INFORMATION AND DESIGN HEREIN WAS ORIGINATED BY AND IS THE PROPERTY OF SKYLOCK INDUSTRIES INCORPORATED. SKYLOCK INDUSTRIES INCORPORATED RESERVES ALL PATENT, PROPRIETARY, DESIGN MANUFACTURING, REPRODUCTION, USE AND SALES RIGHTS THERE TO, AND TO ANY ARTICLE DISCLOSED THEREIN EXCEPT TO THE EXTENT RIGHTS ARE EXPRESSLY GRANTED TO OTHERS. THE FOREGOING DOES NOT APPLY TO VENDOR PROPRIETARY PARTS.

REVISIONS

ZONE	LTR	DESCRIPTION	DATE	APPROVED
	J	REDRAWN	6-10-96	T. CSIK
	K	SHT. 2 FOR -411/-413, ADDED DIM. 1.15, ADDED NOTE NUT ENGAGES APPROX. ONE THD. AT SKYLOCK FINAL ASSY	7-1-98	T. CSIK
	L	SEE ECN L	7-20-98	T. CSIK
	M	SEE ECN M		

NOTES: UNLESS OTHERWISE SPECIFIED.

- MAT'L REF.: SPIGOT BODY, AND PUSH BUTTON; ALLOY 360, FREE MACHINING BRASS- PER ASTM B16 OR EQUIV.
VALVE ASSY; 303 CRES, COND. A, PER AMS-5640N OR EQUIV.
- DECORATIVE FINISH REF.: SPIGOT BODY AND PUSH BUTTON; BRIGHT POLISH, AND BRIGHT CHROME PLATE PER QQ-C-320 TYPE II, CLASS 1.
CRES PARTS PASSIVATE PER QQ-P-35, OR EQUIV.
- APPLICABLE TO FAA-PMA REPLACEMENT OR MODIFICATION PARTS ONLY.
PER FAR 45.15, PARTS WILL BE IDENTIFIED WITH:
 - FAA-PMA.
 - SKYLOCK IND. INC.
 - PART NO.
 - AIRCRAFT INSTALLATION ELIGIBILITY.

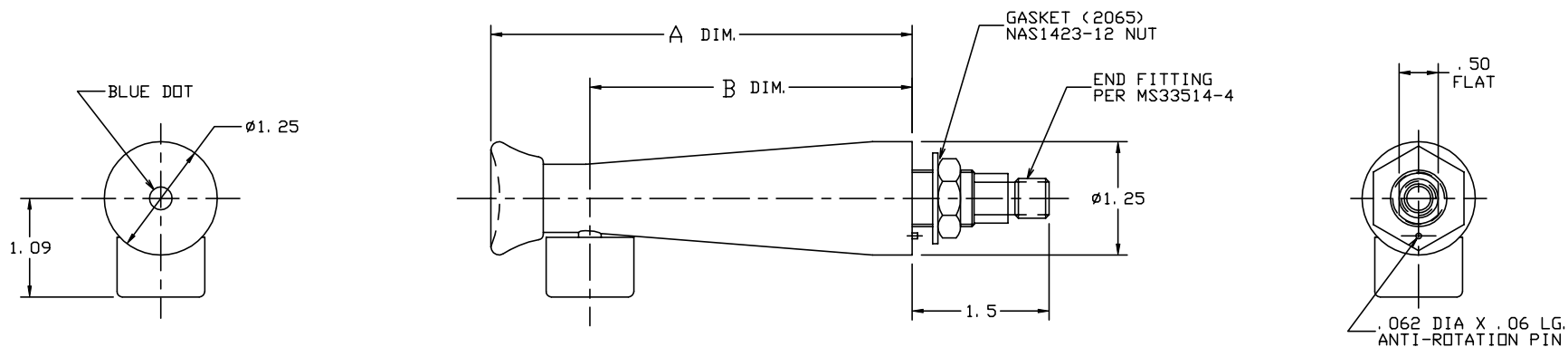

-401, -403, -409 SPIGOT ASSY

2.00	3.25	-413	SPIGOT ASSY		190042-413
2.00	3.25	-411	SPIGOT ASSY		190042-411
1.46	2.80	-409	SPIGOT ASSY		190042-409
2.46	3.80	-407	SPIGOT ASSY		190042-407
3.56	4.66	-405	SPIGOT ASSY		190042-405
2.46	3.80	-403	SPIGOT ASSY		190042-403
3.56	4.66	-401	SPIGOT ASSY		190042-401
B	A	PART NO.	DESCRIPTION	MATERIAL SIZE SPECIFICATION	MAKE FROM

PARTS LIST

UNLESS OTHERWISE SPECIFIED

DIMENSIONS ARE IN INCHES

TOLERANCES ON

DECIMALS ANGLES DRILLED HOLES

.X ± .1 ± 0° 30' AND 10387

.XX ± .03

.XXX ± .010

DO NOT SCALE THIS DRAWING

MATERIAL - FINISH

NEXT ASSY

MANUFACTURE IN ACCORDANCE WITH SKYLOCK IND. INC., QUALITY CONTROL MANUAL QC.001

DRAWN BY T. S.

3-8-89

CHECKED T. CSIK

8/26/99

ENGINEER T. CSIK

8/26/99

DC J. VIVIRITO

8/30/99

MFG P. MATSUOKA

8/26/99

SKYLOCK INDUSTRIES INCORPORATED
MONROVIA CALIFORNIA U. S. A.

SPIGOT ASSY

SIZE CODE IDENT. NO. DRAWING NO.

C

51941

90042

REV. M

SCALE 1/1 & NOTED

SHEET 1 OF 2

FLUID MEDIA	TYPE	OPERATING PRESSURE	OPERATING TEMP.	FLOW
POTABLE WATER	SELF VENTING & BLEEDING	0-125 PSIG	35°F TO 225°F	100/140 OZ. /MIN. AT 70°F AND 30 P. S. I. INLET PRESSURE

4

3

2

1

THE INFORMATION AND DESIGN HEREIN WAS ORIGINATED BY AND IS THE PROPERTY OF SKYLOCK INDUSTRIES INCORPORATED. SKYLOCK INDUSTRIES INCORPORATED RESERVES ALL PATENT, PROPRIETARY, DESIGN MANUFACTURING, REPRODUCTION, USE AND SALES RIGHTS THERE TO, AND TO ANY ARTICLE DISCLOSED THEREIN EXCEPT TO THE EXTENT RIGHTS ARE EXPRESSLY GRANTED TO OTHERS. THE FOREGOING DOES NOT APPLY TO VENDOR PROPRIETARY PARTS.

REVISIONS				
ZONE	LTR	DESCRIPTION	DATE	APPROVED
		SEE SHT. 1 FOR NOTES		

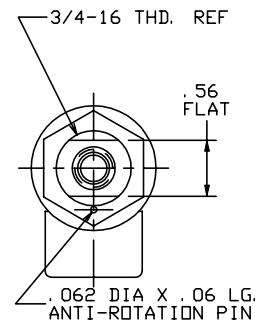
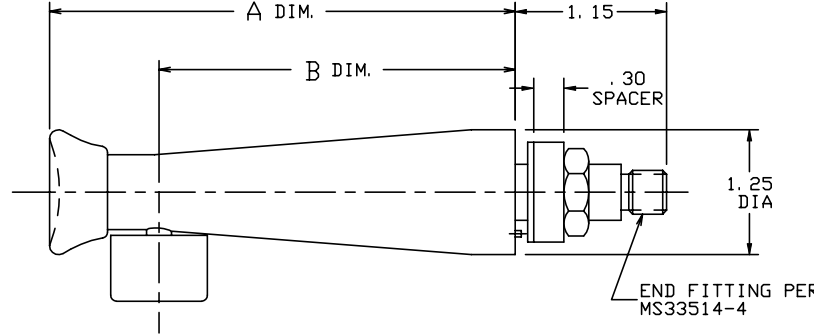
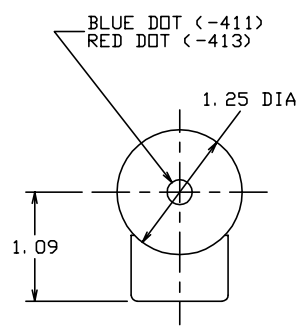

-411 SPIGOT ASSY
-413 SPIGOT ASSY

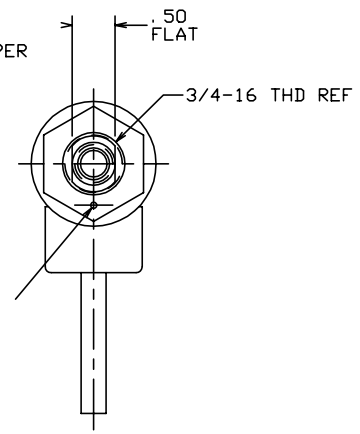
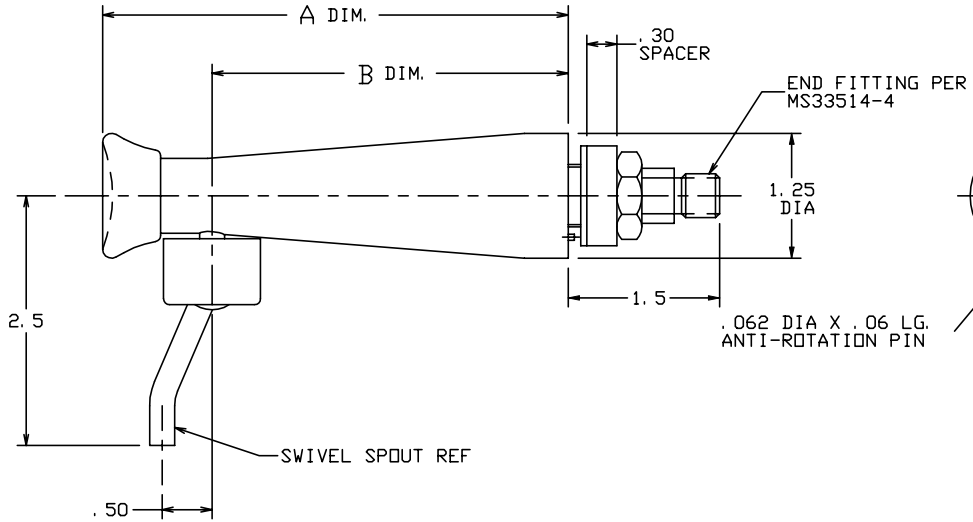
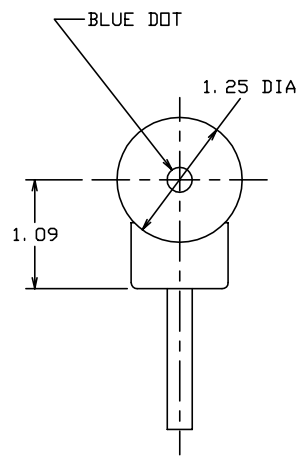

-405 SPIGOT ASSY
-407 SPIGOT ASSY

SKYLOCK INDUSTRIES INCORPORATED
MONROVIA CALIFORNIA U. S. A.

SPIGOT ASSY

SIZE C	CODE IDENT. NO. 51941	DRAWING NO. 90042	REV. M
SCALE 1/1 & NOTED		SHEET 2 OF 2	