

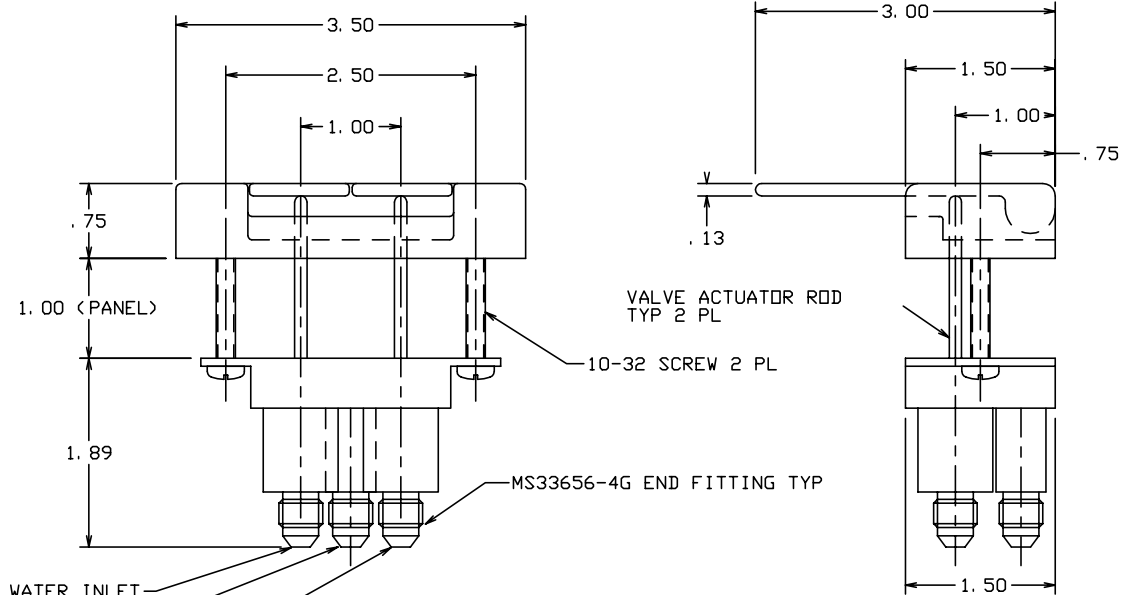

THE INFORMATION AND DESIGN HEREIN WAS ORIGINATED BY AND IS THE PROPERTY OF SKYLOCK INDUSTRIES INCORPORATED. SKYLOCK INDUSTRIES INCORPORATED RESERVES ALL PATENT, PROPRIETARY, DESIGN MANUFACTURING, REPRODUCTION, USE AND SALES RIGHTS THERE TO, AND TO ANY ARTICLE DISCLOSED THEREIN EXCEPT TO THE EXTENT RIGHTS ARE EXPRESSLY GRANTED TO OTHERS. THE FOREGOING DOES NOT APPLY TO VENDOR PROPRIETARY PARTS.

| REVISIONS | | | | |
|-----------|-----|--------------------|---------|----------|
| ZONE | LTR | DESCRIPTION | DATE | APPROVED |
| | NC | PRODUCTION RELEASE | 3-17-93 | T. CSIK |

NOTES: UNLESS OTHERWISE SPECIFIED.
 1. MAT'L: SPOUT, HOUSING, HANDLE; BRASS, VALVE ASSY; CRES.
 2. DECORATIVE FINISH: SATIN CHROME PLATE APPEARANCE SURFACES.

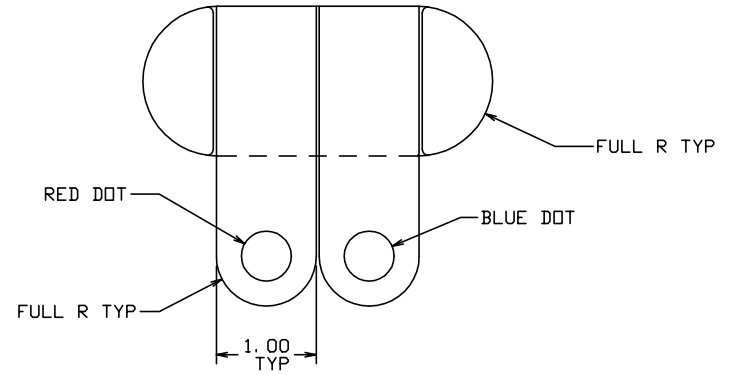
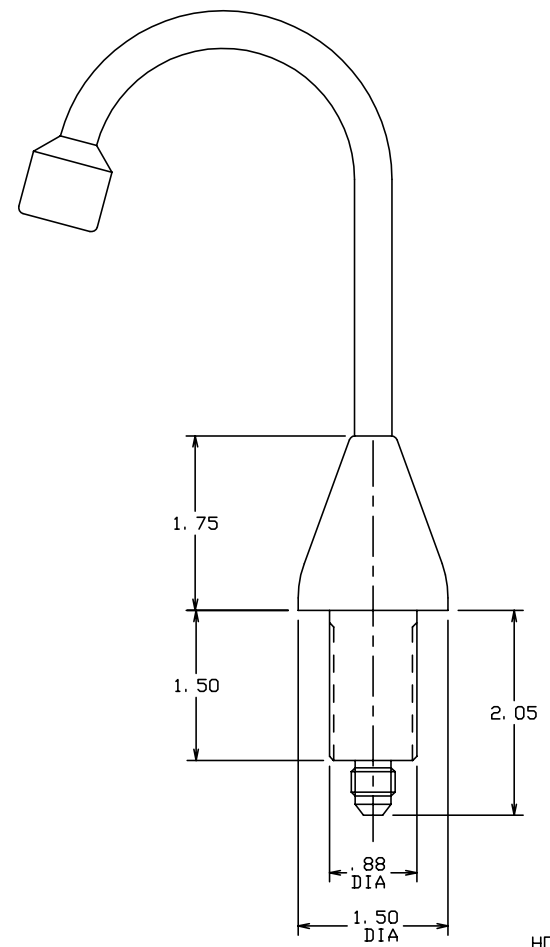

HOT WATER INLET
 COLD WATER INLET
 OUTLET TO SPOUT (BRAIDED HOSE TO CONNECT OUTLET TO SPOUT INLET)

| -401 SWIVEL FAUCET ASSY | | | | | | |
|-------------------------------|----------|-------------|----------|-----------------|---|--------------|
| QTY REQD | PART NO. | DESCRIPTION | MATERIAL | SIZE | SPECIFICATION | ITEM NO. |
| PARTS LIST | | | | | | |
| UNLESS OTHERWISE SPECIFIED | | DRAWN BY | T. CSIK | 3-17-93 |  SKYLOCK INDUSTRIES INCORPORATED MONROVIA CALIFORNIA U. S. A. | |
| DIMENSIONS ARE IN INCHES | | CHECKED | | | | |
| TOLERANCES ON | | ENGINEER | | | | |
| DECIMALS ANGLES DRILLED HOLES | | PROJECT | | | | |
| .X ± .1 ± 0° 30' AND 10387 | | APPROVAL | T. CSIK | 3-17-93 | SWIVEL FAUCET ASSY | |
| .XXX ± .010 | | APPROVAL | | | | |
| DO NOT SCALE THIS DRAWING | | | | | | |
| MATERIAL - FINISH | | USED ON | SIZE | CODE IDENT. NO. | DRAWING NO. | REV. |
| NEXT ASSY | | | C | 51941 | 90068 | NC |
| FINAL ASSY | | | SCALE | 1/2 | WT. | SHEET 1 OF 1 |